

199

101

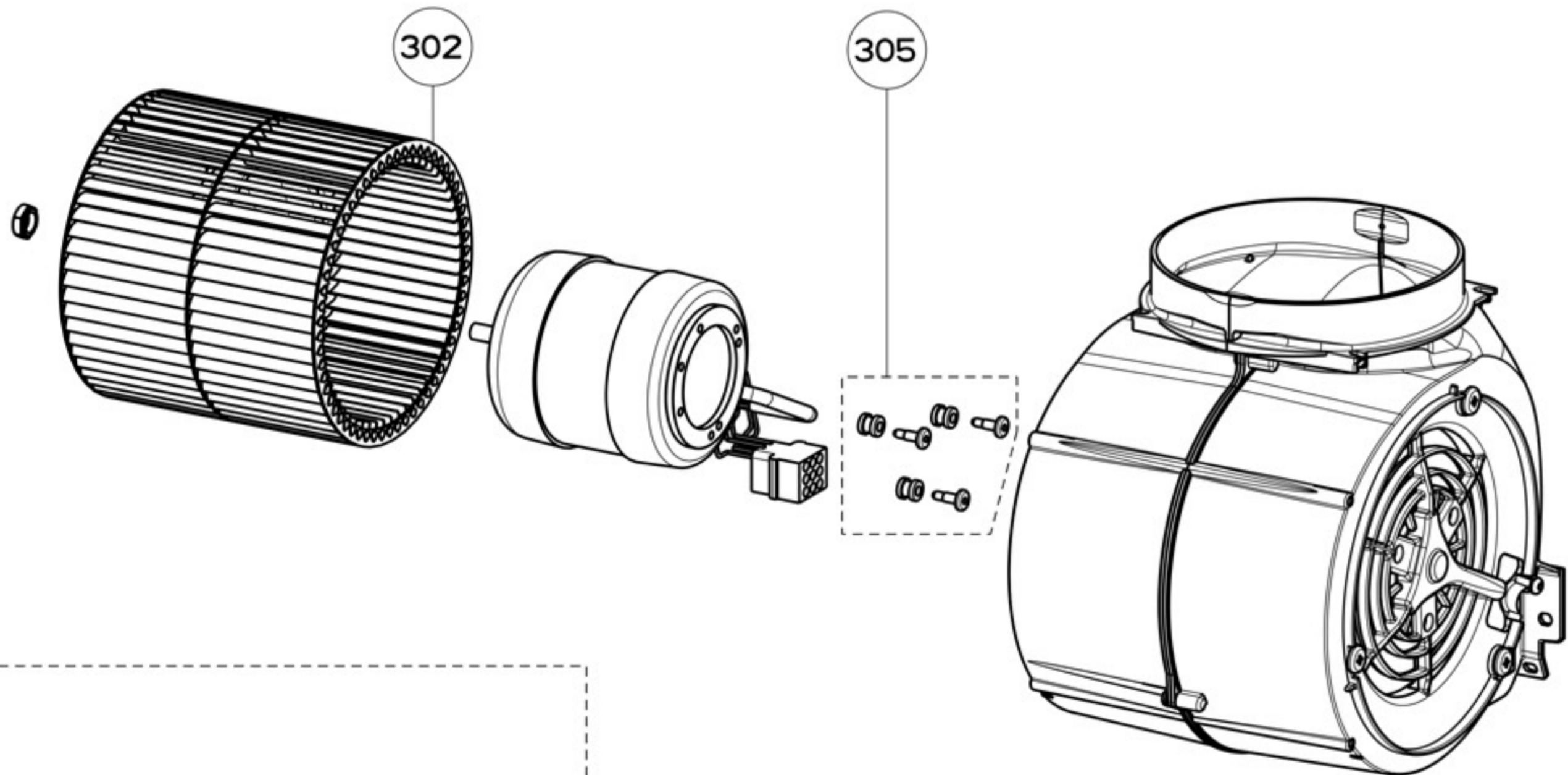

302

305

330

399

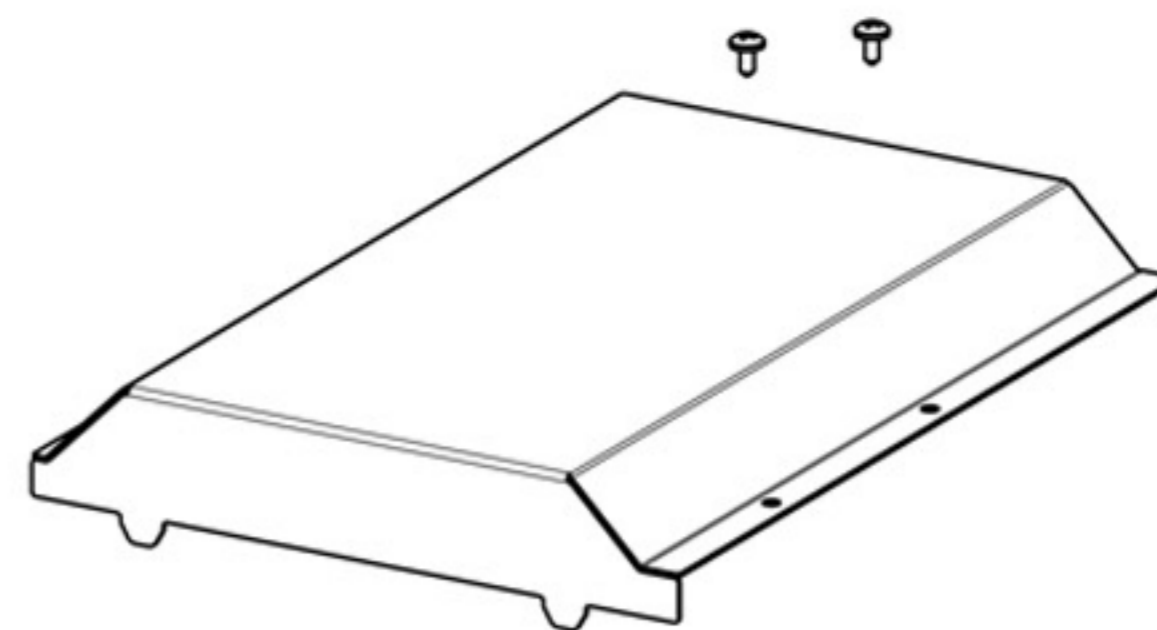
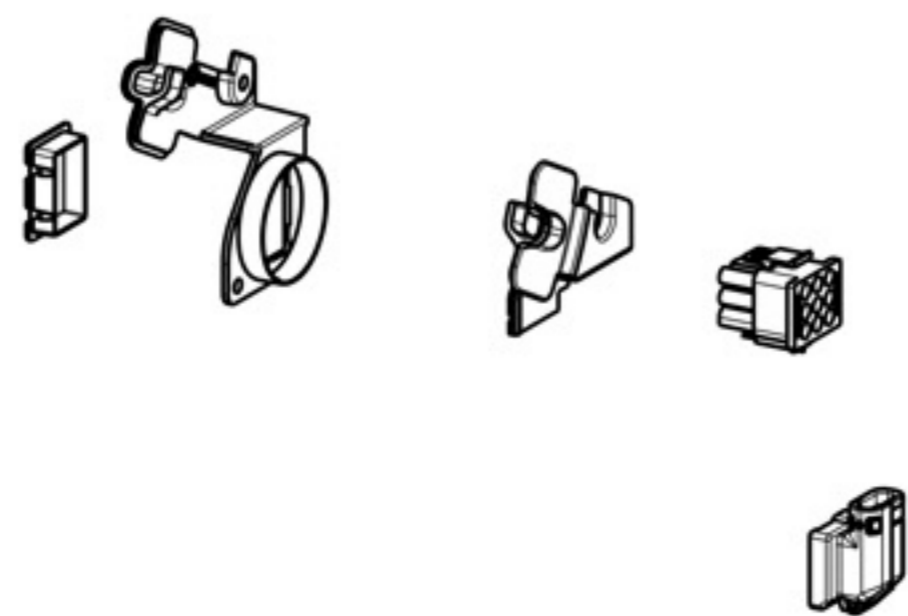

451

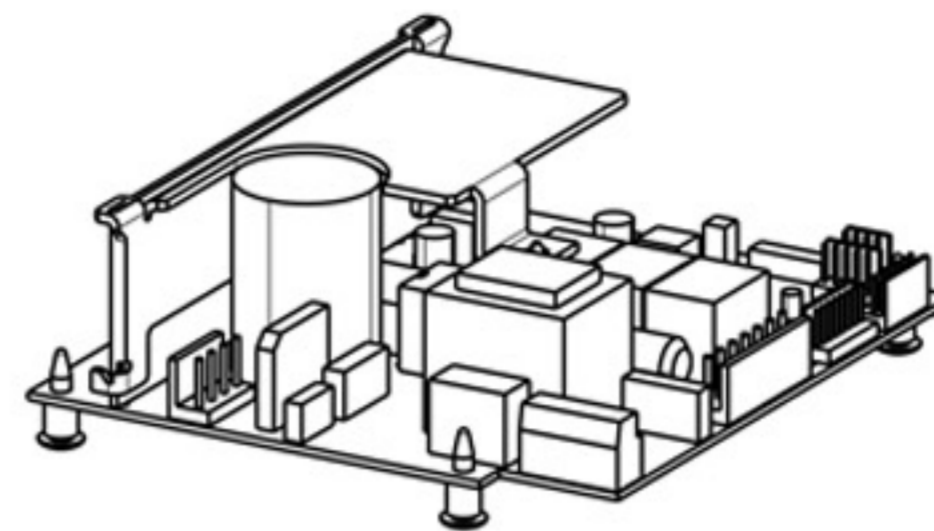

456

455

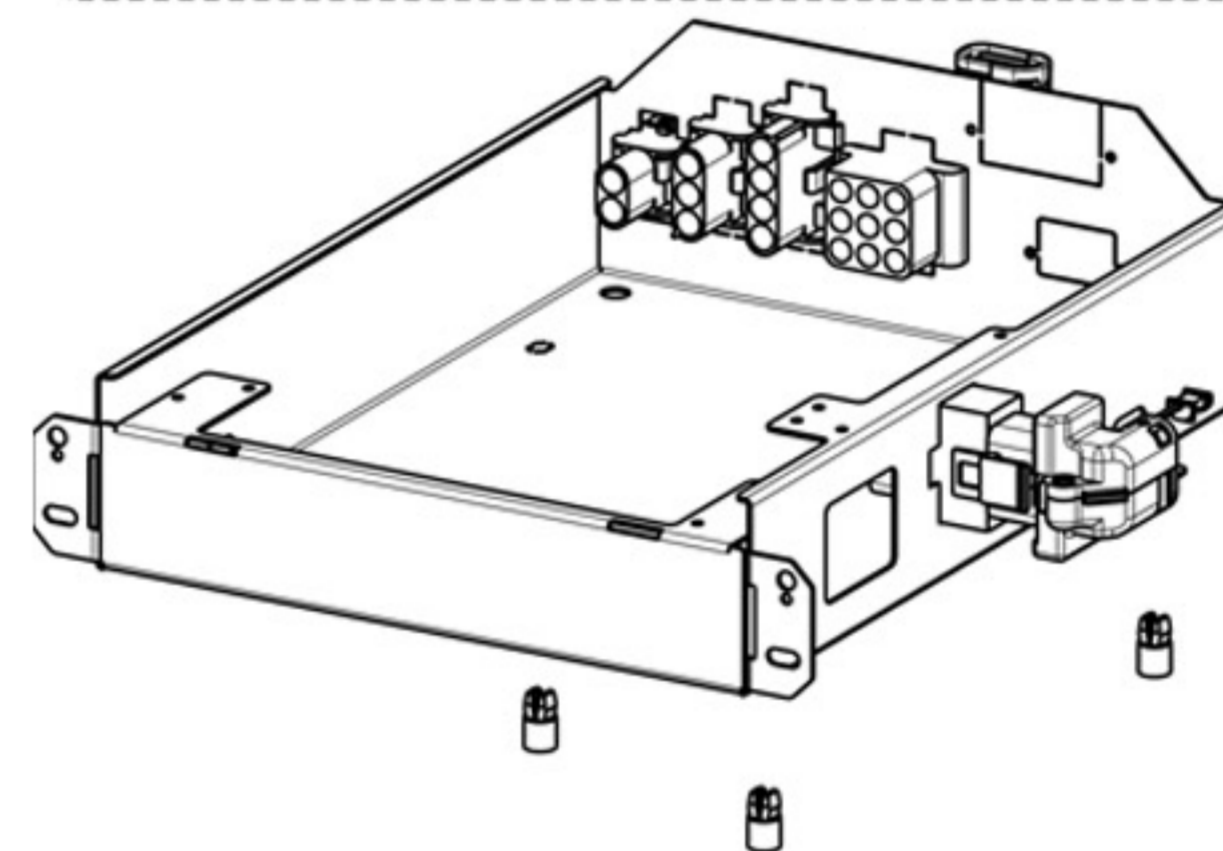
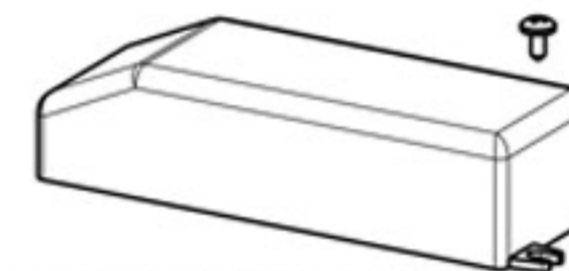
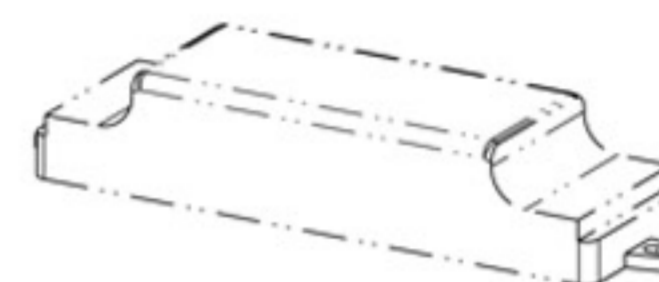

453

454

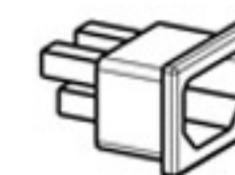
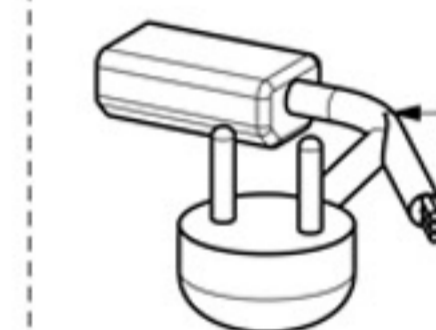

457