

4-in-1 Instant boiling water system

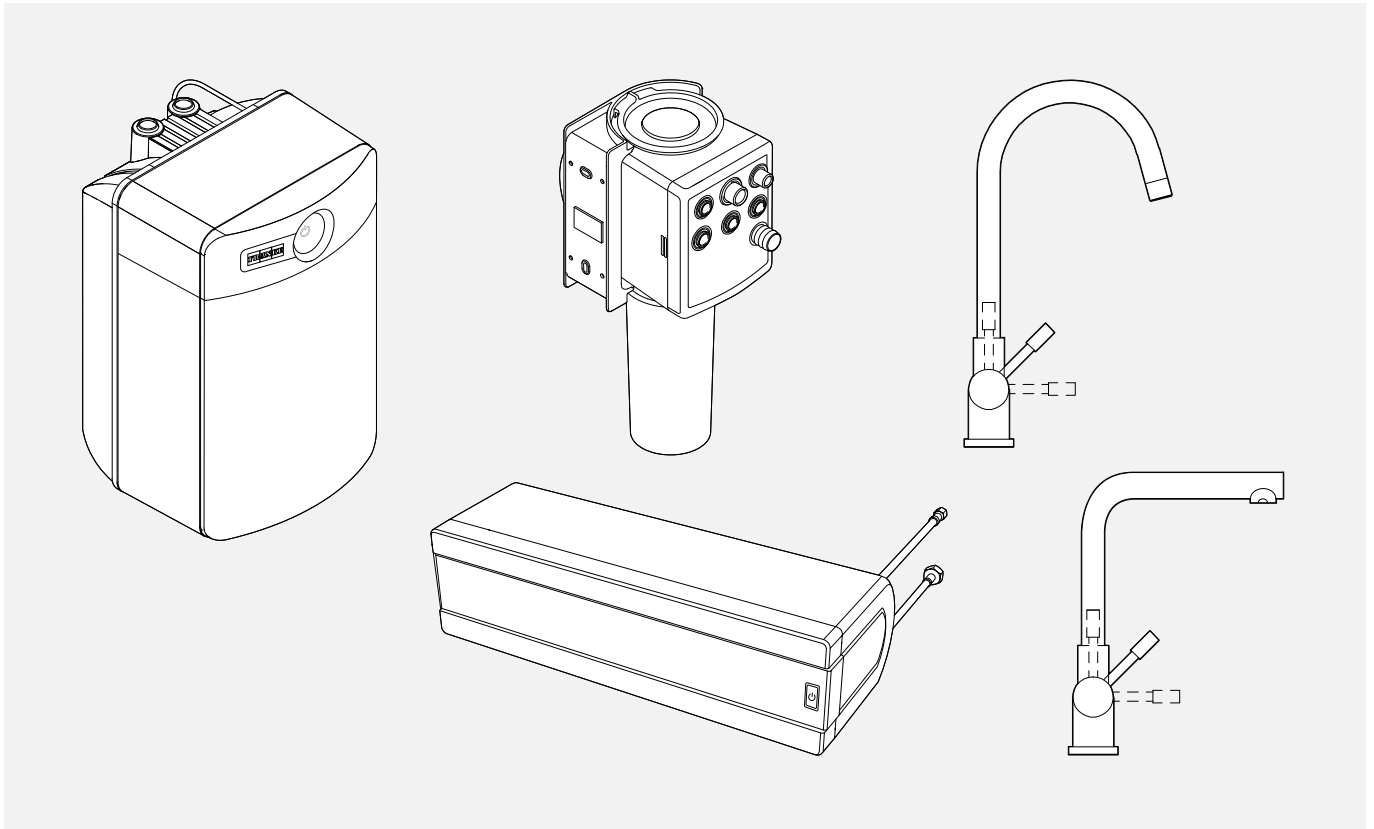

EN Installation and user manual

4-in-1 Instant boiling water system

Table of contents

About this manual	5
Safety information	5
General	5
4-in-1 tap	6
Boiler	6
M-Box	6
Filter cartridge	6
Water quality requirements	7
Installation instructions	7
Warranty	7
Product Information	7
System	7
M-Box	7
Boiler	8
Installation	8
General starting points for installation	8
Installation video	8
Installation steps	8
Installation instructions for push fitting	9
Icon legend	22
Standard installation	33-35
Hot water supply installation	36
Optional Bypass installation	37
Operation	9
Operation of boiler	9
Boiler ECO mode	9
Frost protection	10
Legionella prevention	10

Setting the boiler filter	10
Switching on the boiler	11
Flushing the boiler	11
Decommissioning boiler	11
Taking boiler out of service	12
Operation of mixer lever	12
Operation of selector knob	12
Selector knob status indicator LED	13
Setting filter alert	14
Messages and malfunctions	15
Resetting boiler faults	15
Boiler messages	15
5L Boiler malfunction LED	15
10L Boiler malfunction LED	16
Tap messages	16
Troubleshooting	17
Maintenance	19
General maintenance	19
Replacing filter cartridge in electronic 4-in-1	19
Descaling tap sieve	20
M-Box	20
Disposal	21
Declaration of Conformity	21

About this manual

This manual contains important information on the safe and proper installation and commissioning of the product.

FRANKE reserves the right to make modifications to the product without prior notice. All information correct at time of issuance.

- ▶ Carefully read the user manual before using the device.

- ▶ Keep the user manual.
- ▶ Use the device described in this user manual only according to the intended use.

Symbol	Meaning
	Warning symbol. Warning against risks of injury.
▶	Action step. Specifies an action to be done.



Warning symbol. Warning against risks of injury.



Action step. Specifies an action to be done.

Safety information

General

 Install the product as described in this manual and in accordance with the applicable installation, safety and local water supply regulations.

 Do not use the product for purposes other than those for which it is intended as described in this manual.

 The product must not be modified.

 This product and/or system may be operated by children above the age of 12 and by persons with reduced physical, sensory or mental capacities, or who lack the necessary experience or knowledge, only under supervision or after being instructed in the safe use of the product and when they are aware of the hazards that may arise from the use of the product and/or system.

 Cleaning and maintenance by the user must not be performed by children or by persons with reduced physical, sensory or mental capacities, or who lack the necessary experience or knowledge, without supervision.

 Prevent children from playing with the product and/or system.

 This product and or system is intended for use in domestic and similar environments, such as:

- Staff kitchens in stores, offices and other working environments;
- By guests in hotels, motels and other similar residential environments;
- Bed and breakfast accommodation and other similar residential environments.

Note: See page 8 for the heating time of the system.

 Use in other environments in consultation with the manufacturer of the product and/or system.

 If the power lead with plug is damaged, it must be replaced by the manufacturer, the manufacturer's customer service or a qualified person in order to avoid risks.

 If necessary, lubricate O-rings only with silicone oil.

 In order to avoid freezing, the product may only be installed in frost-free rooms.

 Safety instructions must be observed in order to avoid physical injury and/or damage to the product and/or system.

 Maintenance instructions must be observed in order to avoid damage and excessive wear.

 As a result of the ongoing improvement of our products and/or systems, illustrations in this document may differ from the appliance as delivered.

 If available, you can download the latest version of the manual via our website: **www.franke.com**

 Franke cannot be held responsible for costs, damage or personal injury if the product is not operated in accordance with the instructions given in this manual.

 Tap, M-Box and boiler model may differ from the model illustrated in the manual.

 Ensure there is sufficient ventilation for the tank to avoid overheating.

4-in-1 tap

 Avoid burns and scalding and pay attention when using hot water. The temperature of the hot water may be higher than 55°C.

 Avoid burns and scalding and pay attention when using boiling water. The temperature of the water may be higher than 100°C.

 Tiled and stone sinks will not withstand boiling water; the difference in temperature can cause these to crack. Always open the cold water tap when pouring out boiling water and preferably pour the boiling water directly into the drain.

Boiler

 Before commissioning, ensure that the boiler is filled with water.

 Never pick up or carry the boiler with the hoses or the mains lead.

M-Box

 The appliance must be connected always with the cold water supply.

 Before installation of the M-Box make sure that the drain outlet port of the M-Box is at least 12 cm above the connection of the waste pipe.

 The drain hose must be connected with a continuous downwards gradient to ensure that the M-Box drains correctly, therefore please note you may need to cut the drain hose. The connection point of the drain hose should be downline of the sink siphon.

Filter cartridge

 The use of a water filter is mandatory to protect the product against lime scale deposits.

 After storage at a temperature of 0°C, the filter must first be stored for 24 hours at room temperature before it is installed.

 The filter cartridge must not be opened or damaged.

 The filter cartridge and the system must be intensively flushed after a prolonged standstill period and/or during maintenance work (2 litres of flushing water after 1 week standstill; 10 litres of flushing water after 4 weeks' standstill).

 The filter cartridge must be replaced if, after commissioning, it has not been in operation for 3 months.

Water quality requirements

pH value	7 – 9.5
Waterhardness	3 - 20°dH / 14 - 21°F / 15 - 25°E/Clark
Iron content (Fe)	< 0.2 mg/l
Chlorine content (Cl)	< 150 mg/l
Conductivity	< 125 mS/m
Chemical additions	Not permitted

Installation instructions

⚠ Caution: Never use serrated tools in order to avoid damage. Where necessary, always use the appropriate tools for tightening the coupling.

- Minimum bending radius after installation.
- Without bends after installation.
- Without bend immediately after connection.
- Without tension after installation.
- Without torsion after installation.

Warranty

Scan the QR code to reach the Warranty guidelines:



Product Information

System

Water supply pressure (min.)	200 kPa / 29 psi / 2 bar
Water supply pressure (max.)	400 kPa / 58 psi / 4 bar
Flow rate boiling water	2 - 4 l/min *
Flow rate filtered water	2 - 4 l/min *
Flow rate cold water	5 - 9 l/min *
Flow rate hot water	5 - 9 l/min *

* The flow rate varies, depending on the water supply pressure and the type of tap.

M-Box

Power supply adapter	230 VAC/24 VDC
Tap connection (electrical)	9-pin connector for 4-in-1 tap
Temperature of mixed water	55°C *
Temperature of boiling water	100°C
Maximum water pressure	400 kPa / 58 psi / 4 bar
Filter system	Franke Pro M filter
Filter cartridge dimensions [HxW]	245 x 95 mm
Ambient temperature	4 - 30°C

* Depending on the cold water temperature

Boiler

Boiler	5 litre	10 litre
Dimensions [H x W x D]	145 x 522 x 200 mm	452 x 300 x 285 mm
Contents	4.7 l	10 l
Voltage	230 VAC	230 VAC
Power	1500 W	2200 W
Load	7.0 A	10 A
Energy consumption at standstill	25 W	28 W
IP classification	IP 24D	IP 24D
Storage temperature	<110°C	<110°C
Heating time [ΔT 100 K]	23 min.	35 min.
Operating pressure (max.)	400 kPa / 58 psi / 4 bar	400 kPa / 58 psi / 4 bar
Suitable for hot-fill **	No	No

** The system must always be connected to a cold water supply.



Please note that some options may not be available in your country.

Installation

General starting points for installation

Perform the following steps before starting installation.

1. Stop valves must already be installed.
2. Close the stop valves.
3. In existing installations, remove the tap, hoses and boiler if still in place.
4. Mark the existing cold and hot water connection.
5. Do not connect the M-Box to a hot water pipe.
6. There must be two wall plug sockets available for connection.

Installation video

Guide for the standard installation for the 4-in-1:
https://youtu.be/4KPGVG_MoZg



Installation steps

1. Installing 4-in-1 tap (see page 23)
2. Installing M-Box (see page 27)
3. Installing 5 or 10 litre boiler (see page 30)
4. Connecting 4-in-1 tap (see page 34)
5. Connecting 4-in-1 tap with hot water out of existing pipe (see page 36)
6. Connecting 4-in-1 tap with the Bypass option (see page 37)
7. Connecting the drain hose (see page 39)
8. Commissioning (see page 41)

Installation instructions for push fitting

Installing the push fitting

- ▶ Push the hose into the push fitting (fig. 2A).
- ▶ Pull the hose carefully up and down and check whether it is fitted securely (fig. 2B).

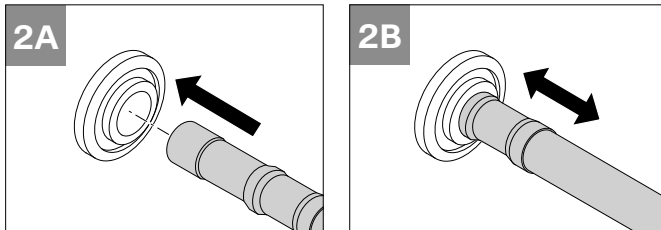

Remove the push fitting

- ▶ Push in the ring on the push fitting (fig. 2C).
- ▶ Pull the hose out of the push fitting (fig. 2D).

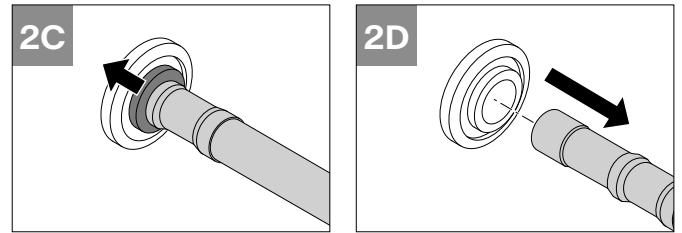

Operation

Operation of boiler

- ▶ Briefly pressing the ON/STANDBY button switches between the boiler modes ON and STANDBY (fig. 4A).

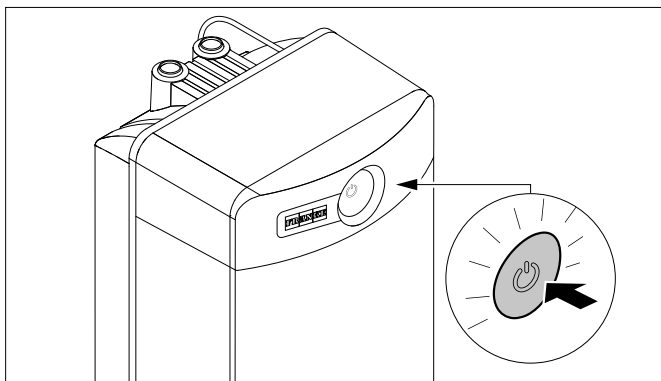
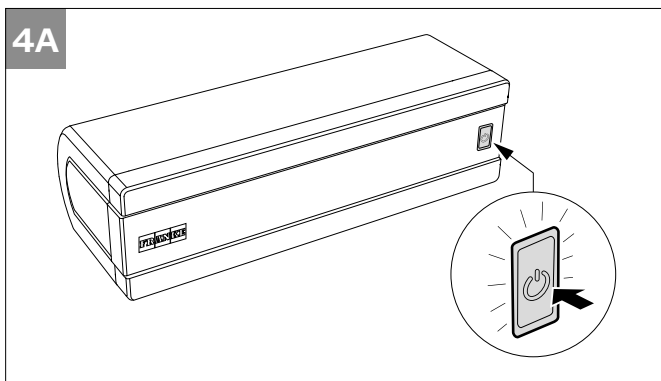

ON:

- The boiler water is heated continuously.
- The operating status of the boiler is indicated by the lit button (see "Boiler messages").

STANDBY:

- The boiler water is not heated.
- The functions "Frost protection" and "Legionella prevention" are active.
- The "ECO function" is deactivated.
- The operating status of the boiler is indicated by the lit button (see "Boiler messages").

OFF:

- The boiler can only be switched off completely by removing the plug from the wall plug socket.

Boiler ECO mode

As long as the boiler is switched on, the temperature of the water is automatically held constant. Boiling water is therefore available at any time of the day. There are, however, times when you don't need boiling water, for example, when you are asleep. In order to prevent the temperature of the boiler being unnecessarily held constant, you can use the energy-saving ECO function.

Whenever the ECO function is activated, the 6-hour night period starts immediately. The boiler water is not heated during the night period. The starting time of this period applies every day as long as the ECO function is activated.

The ECO starting time is not automatically changed at the start of summer and winter time. Then you have to set the starting time again. The ECO function is deactivated if the boiler is switched off by means of a CombiSwitch or in the event of a power failure.

Activating ECO:

The ECO function can only be activated when the appliance is ON.

- ▶ The ECO function is activated by holding the ON/STANDBY button pressed for approx. 3 seconds (fig. 4B).

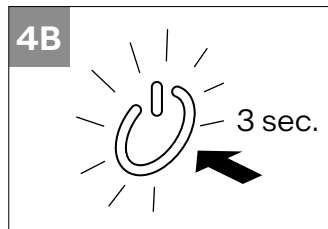

- ▶ The light in the button changes to green as confirmation.
 - ▶ The 6-hour night period starts immediately. The boiler water is NOT heated during the night period unless the water temperature drops to <math><40^{\circ}\text{C}</math>.
- The operating status of the boiler is indicated by the lit button (see "Boiler messages").

Deactivating ECO:

The ECO function can only be deactivated if it has been previously activated.

- ▶ The ECO function is deactivated by holding the ON/STANDBY button pressed for approx. 3 seconds (fig. 4B).
- ▶ The light in the button changes to red, orange or dark blue as confirmation.
- ▶ The boiler is then in ON mode again.

Frost protection

The boiler has a **Frost protection** function that ensures that the boiler water cannot freeze. If the boiler water temperature drops below 5°C , it is heated to 8°C .

The **Frost protection** function can only be activated in STANDBY mode.

Legionella prevention

If the boiler is in STANDBY mode for longer than a week, legionella bacteria may occur. For this reason, the boiler has an automatic LEGIONELLA PREVENTION function.

In the boiler STANDBY mode, a counter is started when the temperature of the boiler water drops below 55°C . After one week (168 hours), the boiler water is heated once to 66°C . Any bacteria in the water will be killed at this temperature.

When the boiler is switched on again, we recommend that the following procedure is observed before use:

- ▶ Wait until the boiler water is up to temperature.
- ▶ Open the boiling water tap and flush the boiling water line until cold water comes out of the tap.

 **Caution:** Ensure that the water does not atomise during flushing. Heat the boiler water again.

 **Caution:** When the boiler has been switched off, the following procedure must always be observed before use.

Setting the boiler filter

 **Caution:** The filter timer is activated as standard (colour setting green).

 **Caution:** If the filter timer of the boiler is activated, heating of the boiler is blocked and the filter cartridge has to be replaced immediately.

The service life of a water filter is dependent on the volume of the filter cartridge and the hardness of the water in your region.

After a certain number of litres of water, your water filter wears out and its effectiveness decreases.

Before use, the filter timer has to be set so that the boiler can signal via the lit button when the filter cartridge has to be replaced.

⚠ Caution: Always switch OFF the filter timer of the boiler if an electronic tap is connected to the boiler.

- ▶ Please ignore the color Red and Purple for the setting.
- ▶ Hold the ON/STANDBY button pressed for approx. 10 seconds.
- ▶ Filter Timer OFF - Dark Blue

⚠ Caution: After 3 seconds, the button has a steady green light. Hold the button pressed until the light starts flashing again!

Setting always starts with the currently set colour flashing.

- ▶ Now choose the right colour by briefly pressing the ON/STANDBY button (repeatedly, as necessary) within 20 seconds.
- ▶ If the button is not pressed within 20 seconds, the boiler goes back to boiler mode. The chosen setting is not saved.
- ▶ Confirm the chosen colour within 20 seconds by holding the ON/STANDBY button pressed for approx. 3 seconds (fig. 4B). The button has a steady light in the chosen colour for 3 seconds to confirm the reset. The filter timer is now set.

After the reset, the operating status of the boiler is indicated by the lit button.

Switching on the boiler

⚠ Caution: The boiler must be completely filled with water.

- ▶ Insert the plug into an earthed wall plug socket. The boiler starts in STANDBY mode. The button has a steady white light.
- ▶ Switch the boiler ON by pressing the ON/STANDBY button. The boiler water is now heated and the operating status is indicated by the lit button.

- ▶ Check the inlet combination after approx. 10 minutes. Expansion water must run off via the drain of the inlet combination (fig. 4C).

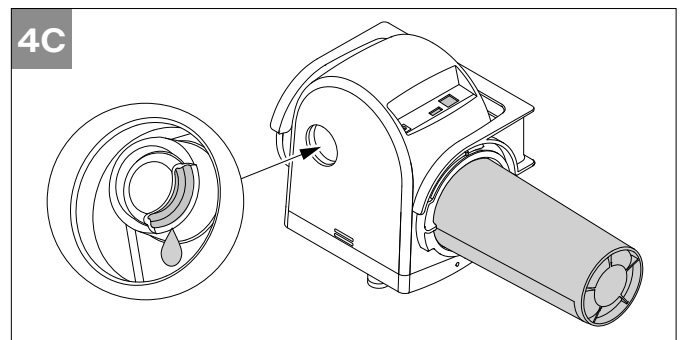

⚠ Caution: If no expansion water runs off during heating, switch off the power supply immediately and open the hot water tap to relieve the water pressure. Refer to the troubleshooting guide.

- ▶ It takes approx. 30–40 minutes to completely heat up a boiler filled with cold water.
- ▶ The boiler water is up to temperature when the ON/STANDBY button has a steady red light.
- ▶ Carry out the following flushing procedure:

Flushing the boiler

- ▶ Leave the water in the boiler for 1 hour after heating.
- ▶ Open the boiling water tap until cold water runs out.
- ▶ Then repeat both steps twice.

⚠ Caution: It is essential to follow the flushing procedure. Also open the cold water tap to prevent the drain from being damaged by the discharge of large amounts of boiling water. The boiler is now ready for use.

Decommissioning boiler

- ▶ Remove the plug of the boiler from the wall plug socket.
- ▶ Turn on the boiling water tap.
- ▶ Wait until cold water runs out.
- ▶ Turn off the boiling water tap.
- ▶ Close the stop valve.

- ▶ Turn on the boiling water tap.
- ▶ Wait until water no longer runs out.
- ▶ Turn off the boiling water tap.
- ▶ Disconnect the hoses from the boiler.
- ▶ Remove the boiler.
- ▶ Allow the water from the hoses and the boiler to drain into the sink.

Taking boiler out of service

If you do not expect to need any boiling water for a prolonged period, such as during holidays, you can switch off the boiler (temporarily):

- ▶ Use the boiler STANDBY mode, or remove the plug from the wall plug socket to prevent heating of the boiler.

Operation of mixer lever

- ▶ Select cold water (fig. 4D).

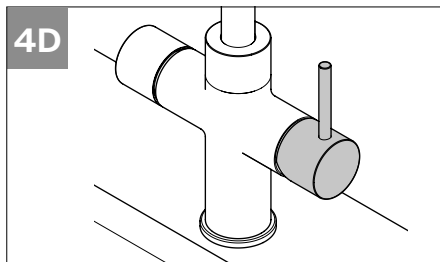

- ▶ Select hot water (fig. 4E).

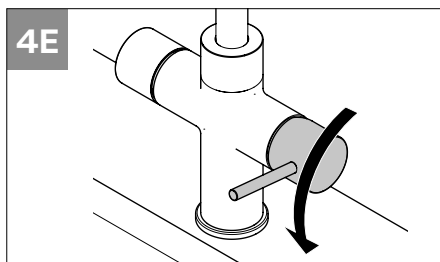

- ▶ Turn on mixer tap (fig. 4F).

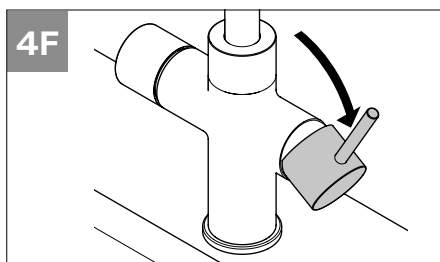

- ▶ Hold the object to be filled close to the tap so that the object surrounds the delivery opening of the tap. This will prevent (hot) water from splashing.

- ▶ For the optimum result when making coffee or tea, allow around 1 cup of water to run out before filling the pot. In this way the air bubbles in the water disappear so that no foam forms on the surface of the tea.

Operation of selector knob

- ▶ Activate tap: Press briefly 1x (fig. 4G).

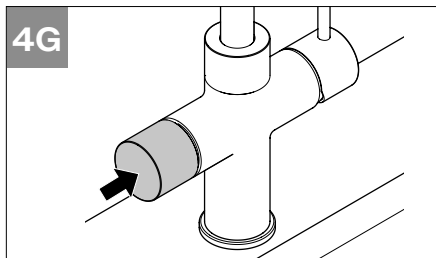

- ▶ Select tap function (fig. 4H).

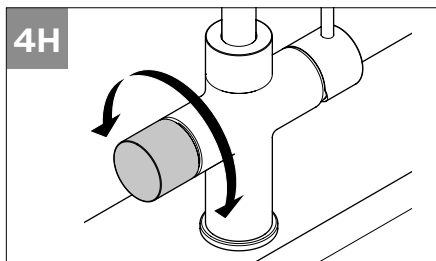

- ▶ Tap level: Hold selector knob pressed (fig. 4I).

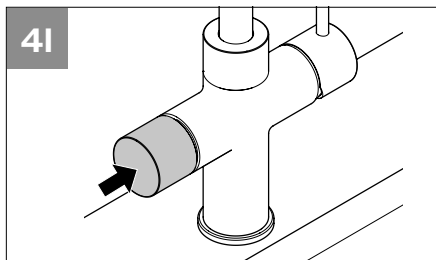

- ▶ Filling mode short: Press briefly 2x. Stops automatically. Deactivate; press briefly 1x (fig. 4J).

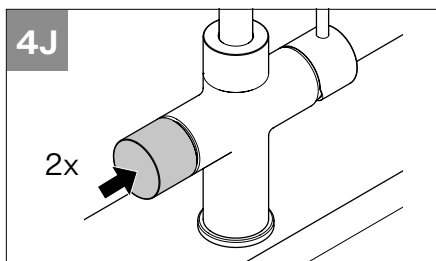

- ▶ Filling mode long: Press briefly 3x. Stops automatically. Deactivate; press briefly 1x (fig. 4K).

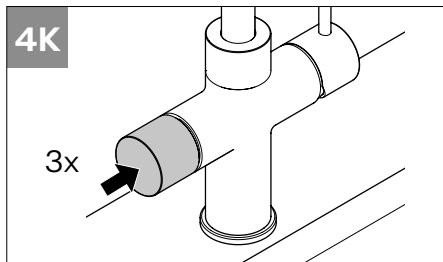

- ▶ Sleep mode/stand-by, light out: Hold depressed for 3 seconds (fig. 4L).

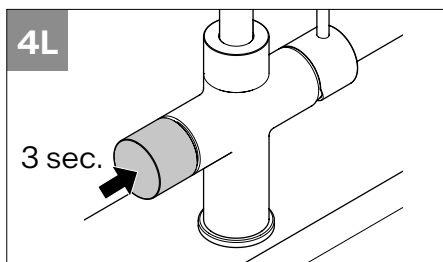

Filling mode short

- ▶ Press 2x briefly for Pan or Carafe refill short.
Pan filling: Boiling water (red) = 30 sec. flow.
Carafe filling: Filtered water = 15 sec. flow.

Filling mode long

- ▶ Press 3x briefly for Pan or Carafe refill long.
Pan filling: Boiling water (red) = 60 sec. flow
Carafe filling: Filtered water = 30 sec. flow.

Selector knob status indicator LED

LED colour	Led action	Function	Button action
Red/Green/Orange/ Purple/Light blue	Alternately	Filter setting mode	See filter settings.
White	Continuous	Stand-by	Turn selector knob to the correct colour for desired tap mode.
White	Pulsating/ Heartbeat	Sleep mode	Press selector knob for awakening.
-	Off	Sleep mode without lighting	Press and hold selector knob for 3 sec.
Red	Continuous	Boiling water	Turn selector knob anti-clockwise.
Blue	Continuous	Filtered cold water	Turn selector knob clockwise.
Red/blue	Alternately	Protection active, the first water dispensed can be hot.	Press the selector knob twice briefly while flashing to cancel the protection function or press and hold selector knob (3 sec.) until the water starts to flow.

Setting filter alert

- ▶ Check the hardness of your tap water on your water supply company's website.
- ▶ Activate tap: Press briefly 1x (fig. 5A).

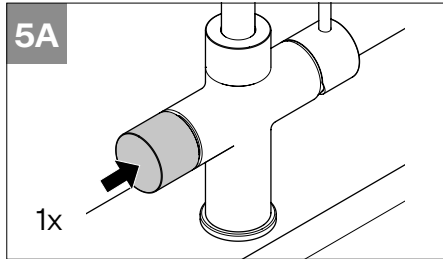

- ▶ Hold depressed for 10 seconds, as LED lights up again (fig. 5B).

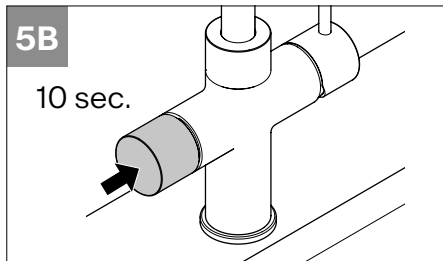

- ▶ Determine the correct color setting based on the table below:

Water hardness			LED colour
°dH	°F	°E / Clark	
3 - 8	5 - 14	4 - 10	Light blue
8 - 12	14 - 22	10 - 15	Orange
12 - 20	22 - 35	15 - 25	Green

- ▶ Please ignore the color Red and Purple for the setting.
- ▶ Choose the right color according to the table above (fig. 5C).

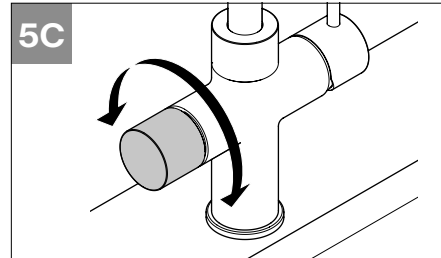

- ▶ Confirm selection: Hold depressed for 5 seconds until the selector knob sounds and the LED flashes (fig. 5D).

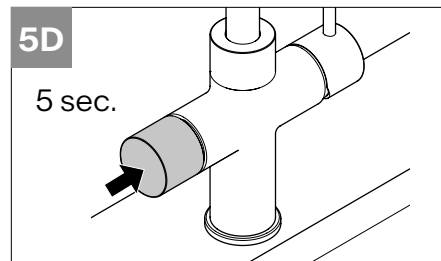

Messages and malfunctions

Resetting boiler faults

If the boiler goes to "fault", you can try to remedy the fault by resetting the boiler.

- ▶ The FAULT RESET function is activated by pressing the ON/STANDBY button for approx. 3 seconds while the fault is displayed.
- ▶ The light in the button goes out to confirm the reset.

- ▶ The boiler restarts in STANDBY mode. The button has a steady white light.
- ▶ The ECO function is deactivated after the reset.



Caution: If you cannot remedy a fault or defect yourself, please contact Franke or your installer. Switch off the boiler by removing the plug from the wall plug socket.

Boiler messages

Boiler status indicator LED

LED colour	LED action	Boiler mode	Description
White	Steady	STANDBY	Heating of boiler water switched off.
White	Steady	STANDBY	Frost protection active.
White	Steady	STANDBY	Legionella prevention active.
Red	Steady	ON	Water temperature > 103°C.
Orange	Steady	ON	45°C < Water temperature < 103°C.
Dark Blue	Steady	ON	Water temperature < 45 °C.
Yellow	Steady	ON	Boiling dry test.
Green	Steady	ECO	Night period active.
Pink	Steady	ECO	Water temperature > 103°C.
Violet	Steady	ECO	45°C < Water temperature < 103°C.
Light blue	Steady	ECO	Water temperature < 45 °C.



Caution: During a fault, the function of the boiler is switched off.

5L Boiler malfunction LED

LED colour	LED action	Description
Red	1 second on / 1 second off	Hardware fault
Red	4 x 0.5 second on / 2 seconds off	Software fault
Red/white	1 second red / 1 second white	Hardware fault - sensor is defective.
Red/yellow	1 second red / 1 second yellow	Boiled selection fault - wrong pcb.
Red/blue	1 second red / 1 second blue	No water pressure.

LED colour	LED action	Description
Red/orange	1 second red / 1 second orange	Maximum protection has tripped - boiler too hot (*).
Red/green	1 second red / 1 second green	Boiler is upside down or installed upright.

* Switch off the boiler and contact Franke technical support.

10L Boiler malfunction LED

LED colour	LED action	Description
Red	Flashes 1x and 2 seconds off	Hardware fault
Red	Flashes 2x and 2 seconds off	Hardware fault - sensor is defective.
Red	Flashes 3x and 2 seconds off	Boiled selection fault - wrong pcb.
Red	Flashes 4x and 2 seconds off	Boiler is upside down or installed upright.
Yellow	Flashes 1x and 2 seconds off	Boiler dry - no water in the boiler.
Yellow	Flashes 2x and 2 seconds off	Maximum protection has tripped - boiler too hot (*).
Yellow	Flashes 3x and 2 seconds off	Water filter cartridge is finished and must be replaced immediately. Heating of the boiler is switched off.

* Switch off the boiler and contact Franke technical support.

Tap messages

LED colour	LED action	Function	Description
Blue / red	Alternately	Protection active, the first water dispensed can be hot.	Press the selector knob twice briefly while flashing to cancel the protection function or press and hold selector knob (3 sec.) until the water starts to flow.
Orange	Pulsating/ Heartbeat	Filter cartridge is almost consumed (90%).	Filter cartridge is almost finished and must be replaced shortly.
Orange	Continuous	Filter cartridge has been used (100%) must be replaced immediately.	Filter cartridge is almost finished and must be replaced shortly.
Orange	Continuous	Filter cartridge has been used (110%) blockade of boiling and filtered water.	Filter cartridge is finished and must be replaced immediately.
Orange	Blinking	No valve has been detected / a valve is defective.	Check the cabling and or the valve.

Troubleshooting

Selector knob is lit or does not respond

Cause	Remedy
Software problem	Disconnect the power supply from the M-Box for at least 10 seconds.
The cable connector of the tap is not correctly connected	Plug the cable connector into the M-Box securely.
The wall plug socket has no power supply	Check the electricity grid and repair the interruption. The electricity group has failed due to an excessive load. The boiler cannot be connected to the same electricity group as a dishwasher.
The cable or connector of the tap is damaged or defective	Contact Franke technical support.
The power supply to the M-Box is defective	Contact Franke technical support.
The M-Box is defective	Contact Franke technical support.

Water leaks

Cause	Remedy
Connection leaking	Inspect the coupling(s) and retighten, if necessary.
Hose(s) leaking	Inspect the hose(s) and replace the leaking hose(s).
Boiler leaking	Remove the plug of the boiler from the wall plug socket. Shut off the water supply. Contact Franke.
Tap leaking	Shut off the water supply. Contact Franke.
M-Box leaking	Remove the plug of the M-Box and the boiler from the wall plug socket. Shut off the water supply. Contact Franke.

Tap supplies no water

Cause	Remedy
Hose(s) kinked	Inspect the hose(s) and straighten the kinked hose(s).
The main water valve is closed	Open the main water valve.
The stop valve in the kitchen cabinet is closed	Open the stop valve.
Filter not installed in M-Box	Install filter in the M-Box.

Tap supplies no boiling water

Cause	Remedy
Hose(s) kinked	Inspect the hose(s) and straighten the kinked hose(s).
The M-Box is defective	Contact Franke technical support.

Tap supplies no filtered water

Cause	Remedy
Hose(s) kinked	Inspect the hose(s) and straighten the kinked hose(s).
The M-Box is defective	Contact Franke technical support.

The water from the tap is not boiling

Cause	Remedy
The plug of the boiler has not been inserted into a wall plug socket	Insert the plug into an earthed wall plug socket.
The wall plug socket has no power supply	Check the electricity grid and repair the interruption. The electricity circuit has failed due to an excessive load. The boiler cannot be connected to the same electricity circuit as a dishwasher.
The boiler is OFF (wait mode)	Switch the boiler ON.
The boiler has not heated up completely	Wait until the boiler has heated up.
The boiler has a fault	Reset the boiler.
The boiler is defective	Contact Franke technical support.
The M-Box is defective	Contact Franke technical support.

Tap supplies no hot water

Cause	Remedy
Hose(s) kinked	Inspect the hose(s) and straighten the kinked hose(s).
Boiler not functioning	See table "The water from the tap is not boiling".
Hot water appliance not functioning (if hot water is not being used from the M-Box)	Consult the manual of your hot water appliance.

The boiler causes a short-circuit

Cause	Remedy
There is a short-circuit in the electric wiring or the heater element of the boiler	Remove the plug of the boiler from the wall plug socket. Contact Franke technical support.

The boiler causes a short-circuit. No expansion water from the M-Box

Cause	Remedy
No water in the boiler	Fill the boiler with water.
The boiler is OFF (wait mode)	Switch the boiler ON.
The boiler has a fault	Reset the boiler.
The boiler is defective	Contact Franke technical support.
Pressure relief valve in the M-Box is defective	Remove the plug of the M-Box and the boiler from the wall plug socket. Shut off the water supply. Contact Franke.

Maintenance

General maintenance

- ▶ Clean the tap only with a little detergent and a damp cloth. Then rinse the tap with some water and wipe it down with a dry cloth.
- ▶ Do not use cleaning agents containing a solvent or acid, such as lime scale removers, household vinegar or cleaning agents with acetic acid. These substances damage the surface. The tap will become matt and scratched.
- ▶ Lime scale deposits can be prevented by drying the tap after use.
- ▶ If lime scale deposits nevertheless occur, remove these using a citric acid-based cleaning agent.
- ▶ Check regularly whether water drips out of the inlet combination. This dripping is a sign that the inlet combination is (still) working correctly.
- ▶ Always use original Franke parts for maintenance or repair. This guarantees the safety and proper function of the product and safeguards any warranty claims.
- ▶ Replacement or repair of parts may only be carried out by Franke Service.

Replacing filter cartridge in electronic 4-in-1

Filter (120.0305.558)

Water hardness			LED colour
°dH	°F	°E / Clark	
3 - 8	5 - 14	4 - 10	Light blue
8 - 12	14 - 22	10 - 15	Orange
12 - 20	22 - 35	15 - 25	Green

During initial commissioning the e-knob is already in the filter position, different LED colour are shown alternately.

Note: If the selector knob is not in the filter position, activate the filter setting by pressing and holding the selector knob for 10 seconds until the colour (last filter setting) is displayed (fig. 7A).

- ▶ Select the correct LED colour (water hardness) by turning the selector knob (fig. 7B).
- ▶ Confirm the chosen colour (water hardness) by pressing the button for 5 seconds (fig. 7C).
- ▶ Selector knob illumination flashes alternately white and chosen colour for confirmation.
- ▶ The selector knob returns to the stand-by position.

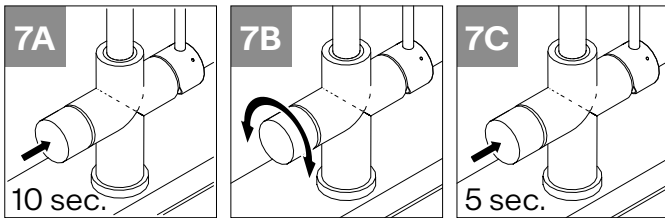

Descaling tap sieve

- ▶ Always use a citric acid-based descaling agent. Other substances will damage the material!
- ▶ Loosening and tightening can be made easier by wrapping an elastic band around the sleeve of the tap sieve. Take care that the sleeve of the tap sieve is not damaged by the use of tools.
- ▶ It is possible that the maximum quantity of water has run through the filter within the year. In this case, the tap will signal that the filter needs to be changed. A new filter can be easily ordered at www.franke.shop
- ▶ Over the course of time, lime scale deposits will appear on and alongside the tap sieve (aerator).
- ▶ Unscrew the sleeve of the tap sieve (fig. 7D).
- ▶ Clean the tap sieve using a suitable descaling agent (fig. 7E).
- ▶ Place the tap sieve into the sleeve (fig. 7F).

- ▶ Place the gasket onto the tap sieve (fig. 7G) and screw on the sleeve finger-tight (fig. 7H).

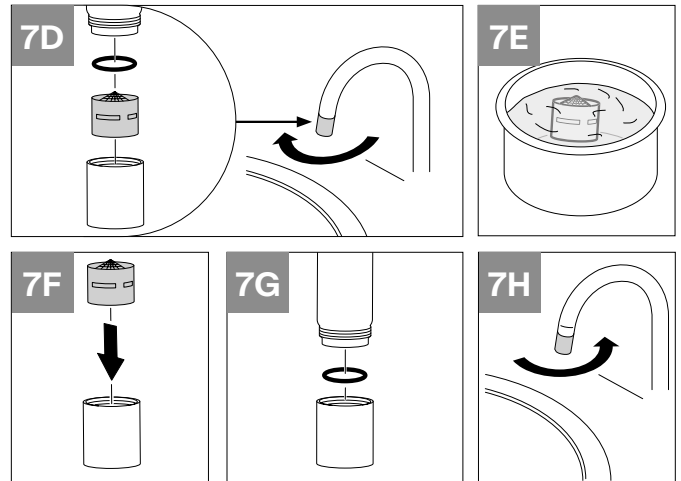

M-Box

- ▶ Check regularly whether water drips out of the pressure relief valve. This dripping is a sign that the inlet combination is (still) working correctly (fig. 7I).

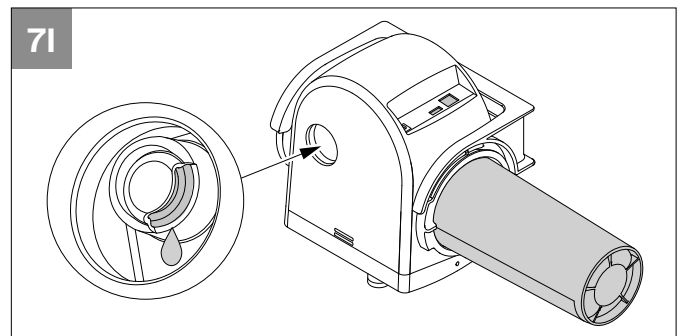

Disposal



The symbol on the product or on the packaging indicates that the device must not be disposed of in the domestic waste.

By disposing of the device in a proper way you help to avoid harmful consequences to environment and health.

Further information about recycling the device is available from the competent authority, the local refuse disposal service or the vendor of the device.

Dispose of the device, which is to be discarded, via a specialised waste collection point for electronic and electrical devices.

In accordance with the article of Legislative Decree no. 15 dated 25 July, Implementation of Directive 2002/96/EC regarding the reduction of the hazardous substances used in electrical and electronic appliances, and waste disposal.

The barred dustbin symbol on the appliance indicates that at the end of its working life the product must not be disposed of as household waste.

Consequently, when the appliance has reached the end of its working life the user must take it to a suitable recycling centre for electronic and electrotechnical waste, or return it to the dealer when purchasing a new appliance of equivalent type.

Proper separate waste collection of the scrapped appliance for subsequent recycling, treatment and environmentally-friendly disposal helps prevent a potentially negative impact on the environment and health and facilitates recycling of the materials used in appliance construction.

Declaration of Conformity

Franke declares that the following product: Boiler 5 litres and Boiler 10 litres are in conformity with the following specifications:

























- EN 60335-1:2012+AC11-:2014 +A11:2014 +A13:2017+:2019 A2:2019 +A14:2019
- EN 60335-2-15:2016 +A11:2018
- EN 50440:2016 =A1 2020
- EN 55014-1:2017 +A11:2020
- EN 55014-2:2015
- EN 61000-3-3:2013
- EN 61000-3-2:2014
- EN 50440:2016 =A1 2020

These products are in conformity with the rules of the low voltage guideline 2006/95/EC and EMC guideline 2004/108/EC.

**UK
CA**

* This product complies with conformity requirements of the applicable UK Regulations.

Icon legend

	Product information		Determine position
	Warning Caution Hazard		Open
	Check on the website		Close
	Tool equipment		Discard
	Scope of delivery		Cut
	Dimensions		Check push fitting
	Montage		Cold water
	Drill		Warm water
	Maintenance		Hot water
	Tighten finger-tight		Do not Forbidden result
	Screw		Do, OK! Result
	Spanner		url video link
	Measure		

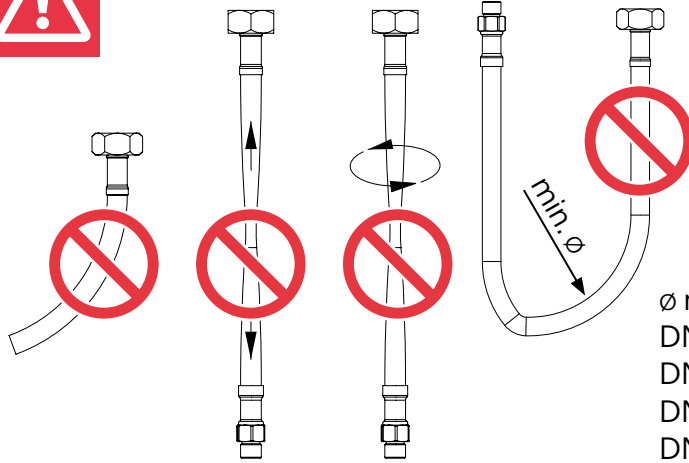

\varnothing min. :
 DN 6 = \varnothing 50 mm
 DN 8 = \varnothing 60 mm
 DN10 = \varnothing 70 mm
 DN13 = \varnothing 90 mm

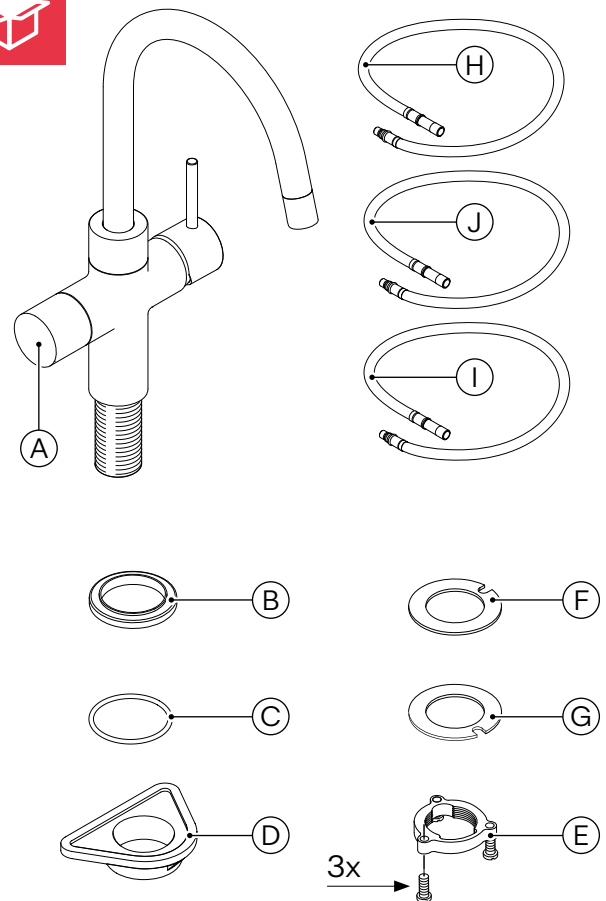
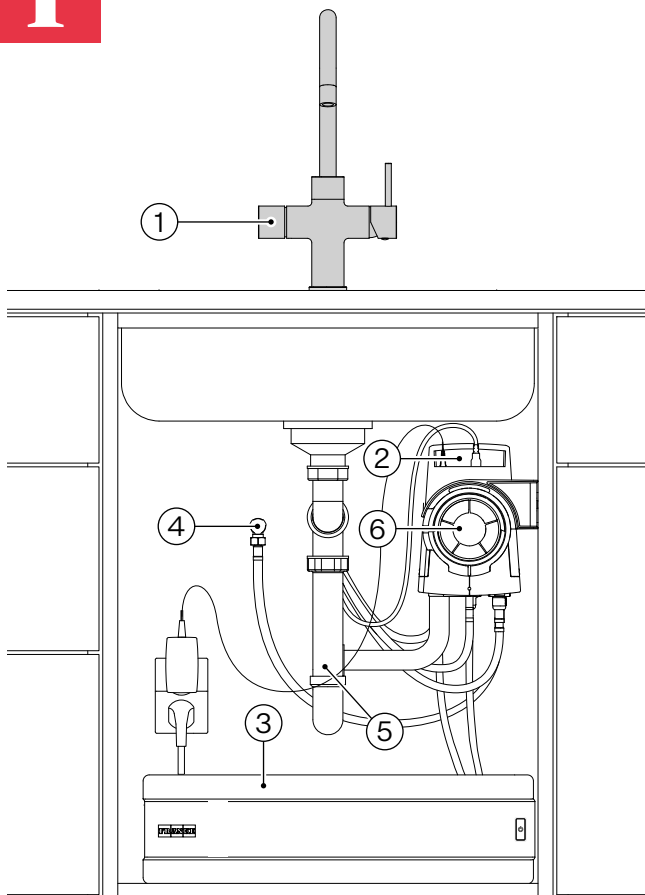
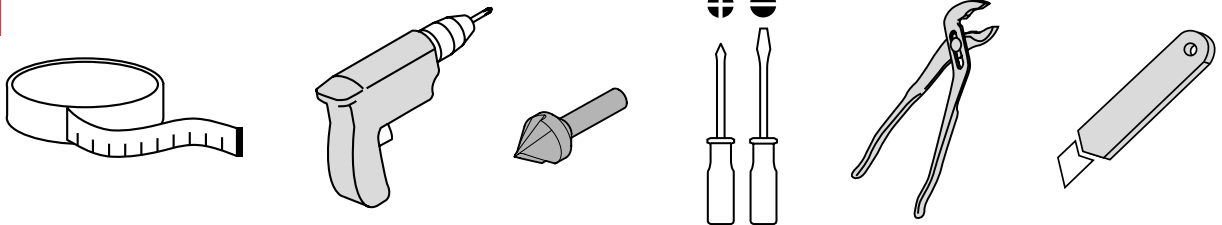

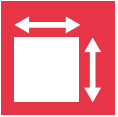

Tap Helix 4-in-1

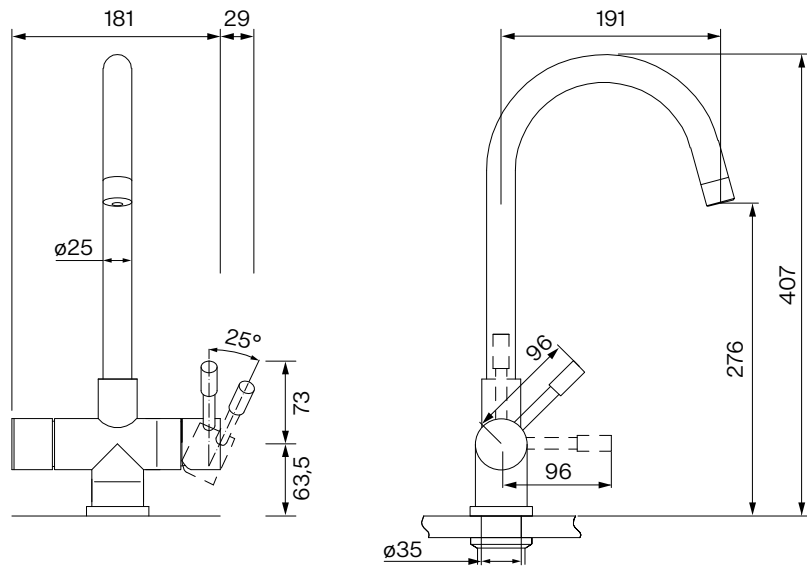

Tap Mondial 4-in-1

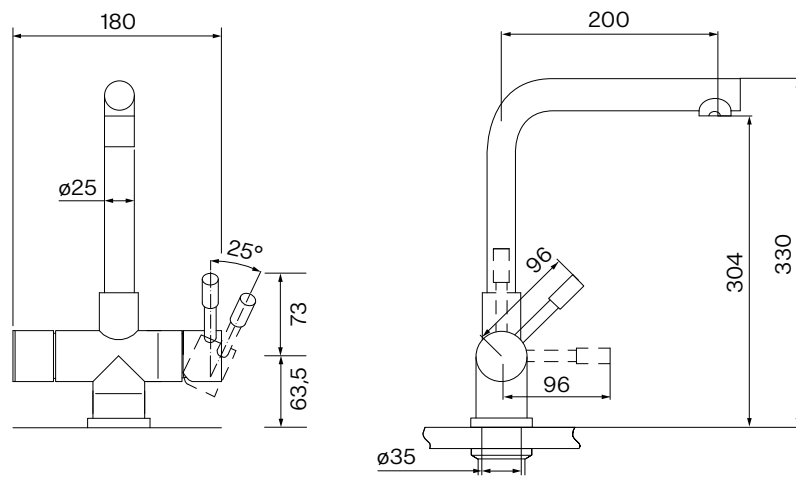

Tap Pollux 4-in-1

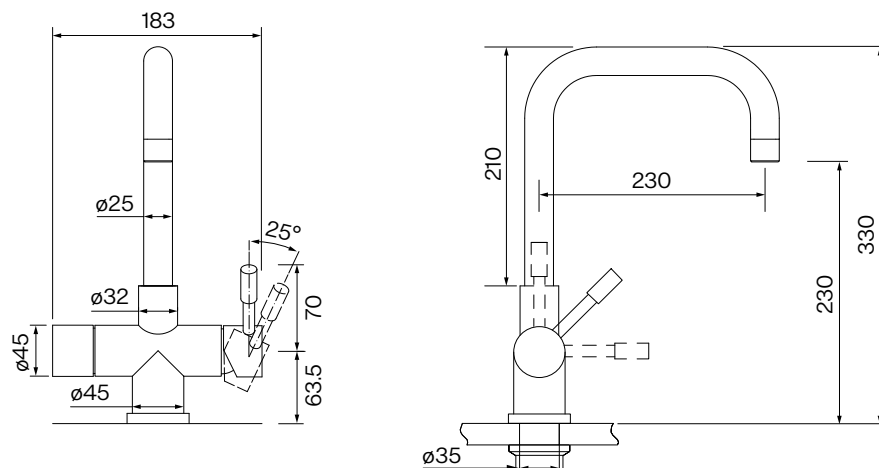

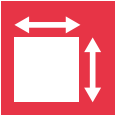

Tap Minerva 4-in-1

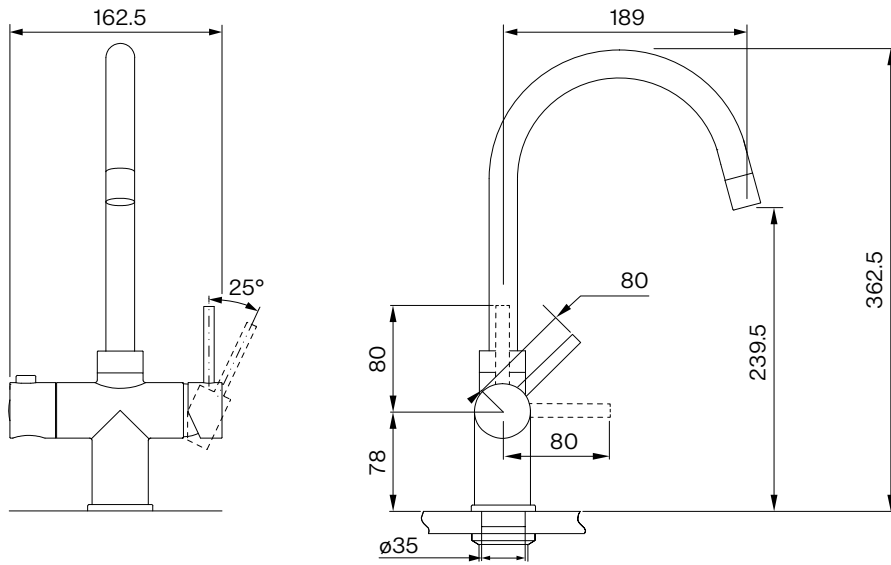

M-Box

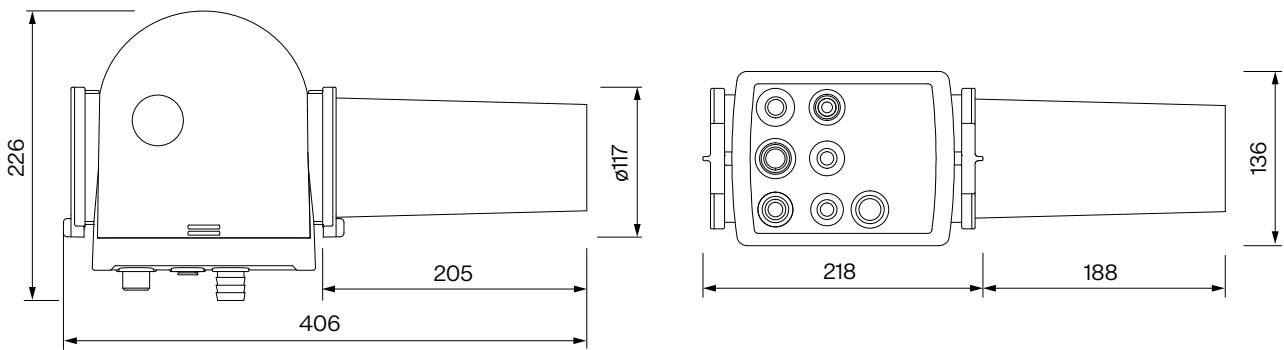

Boiler

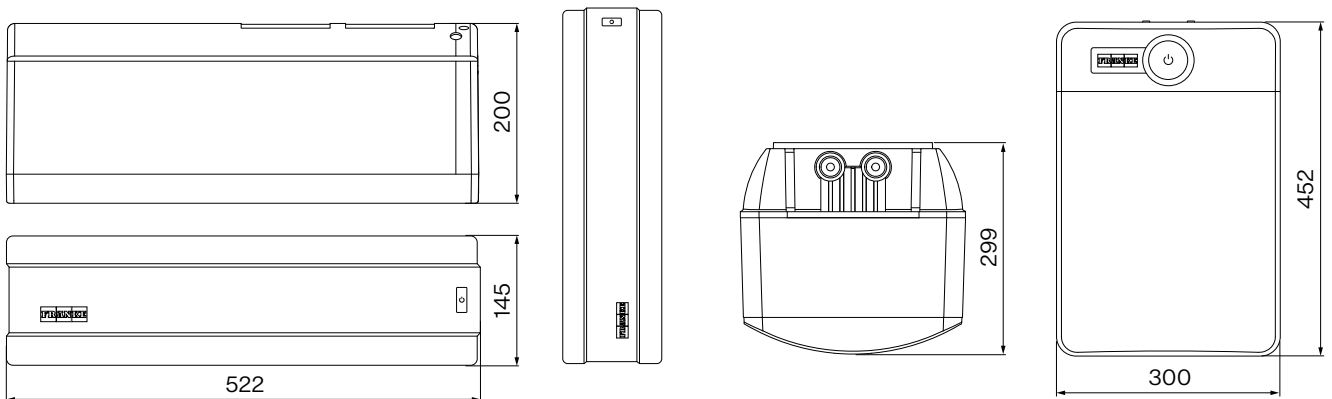

5 litre boiler

10 litre boiler



1

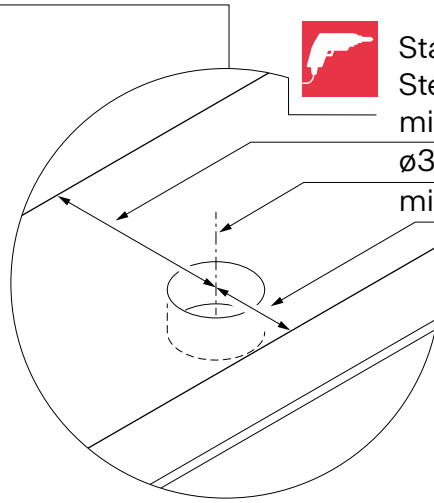
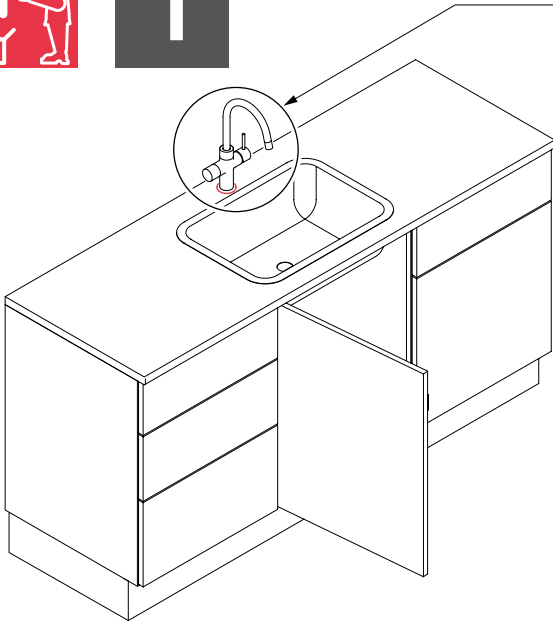

Stainless Steel

Chrome

min. 40 mm

min. 60 mm

ø35 mm

ø35 mm

min. 30 mm

min. 30mm



2

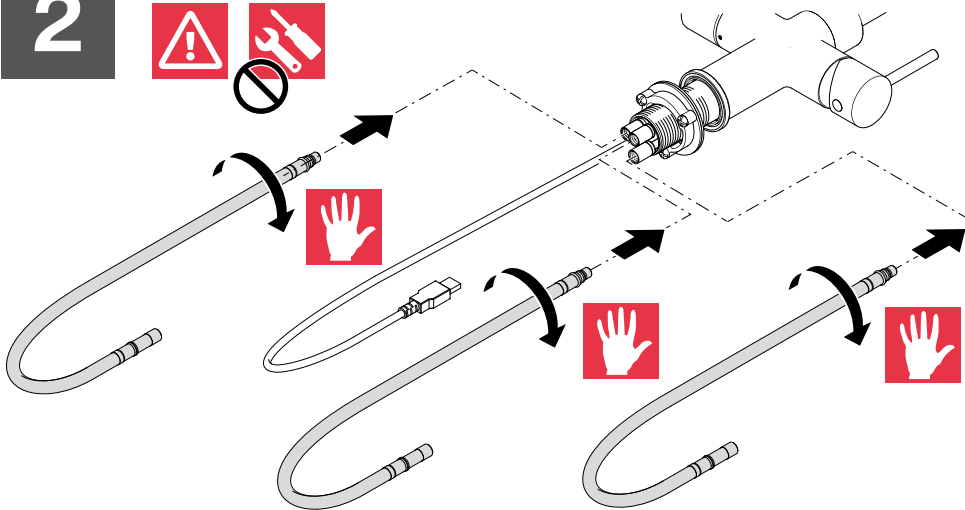

3

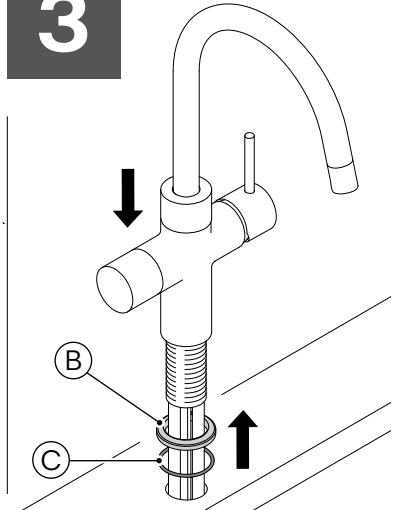

4

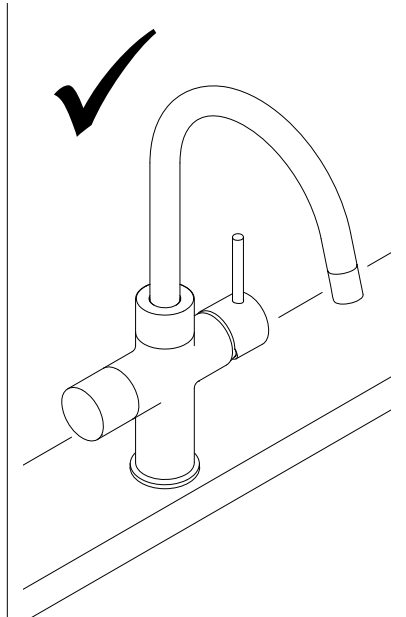
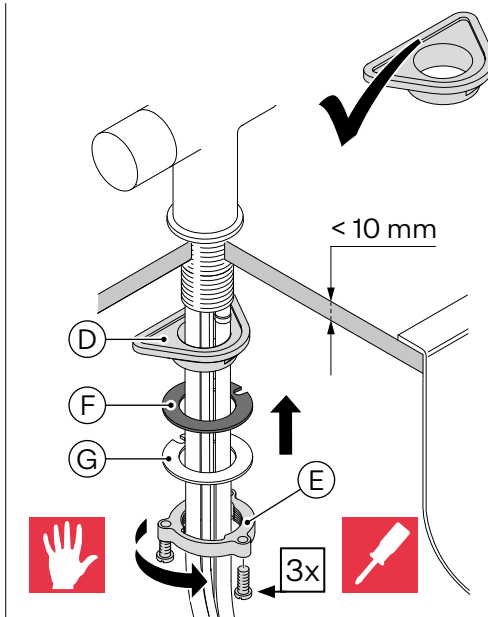
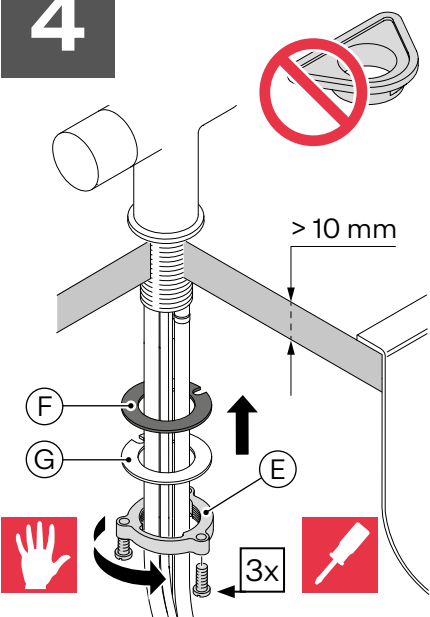

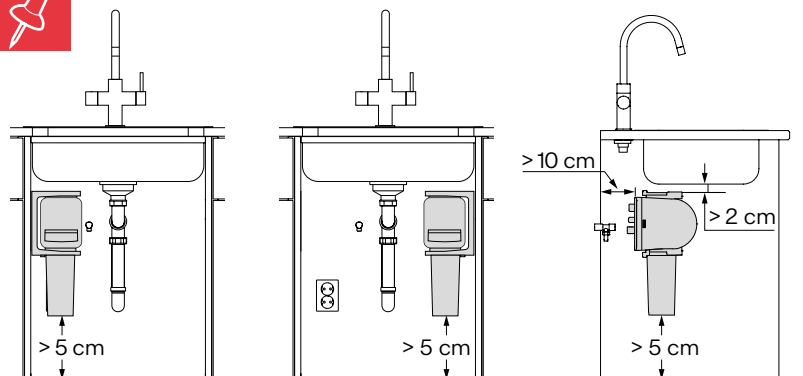
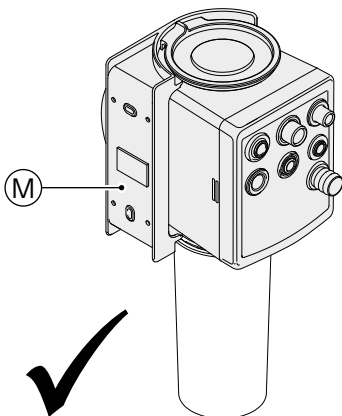
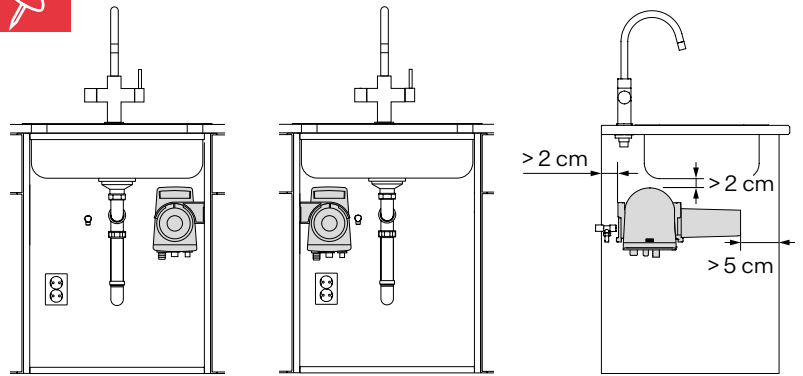
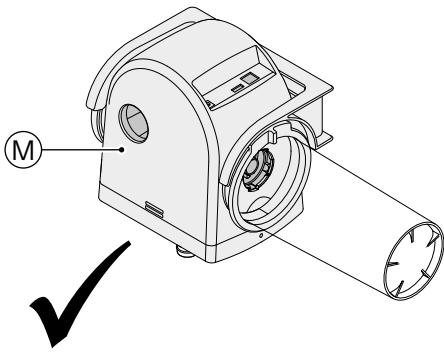
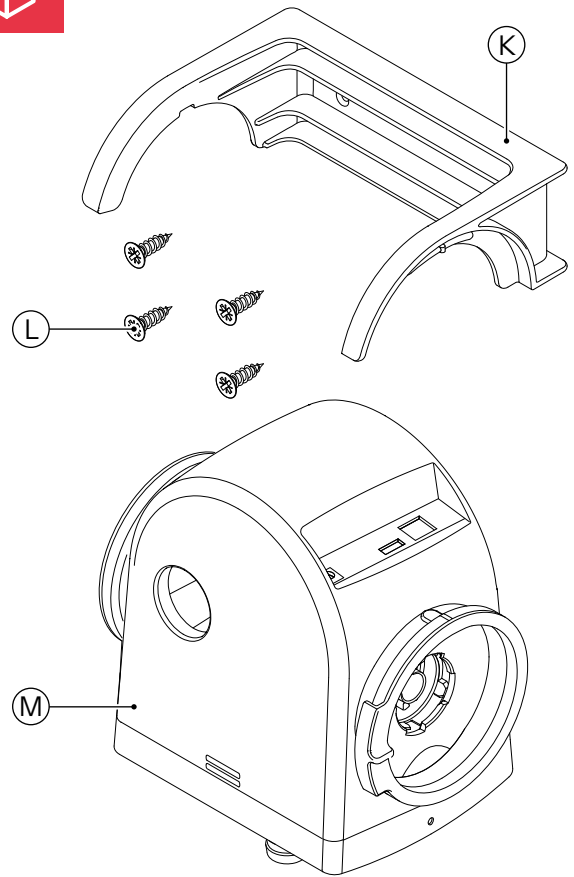
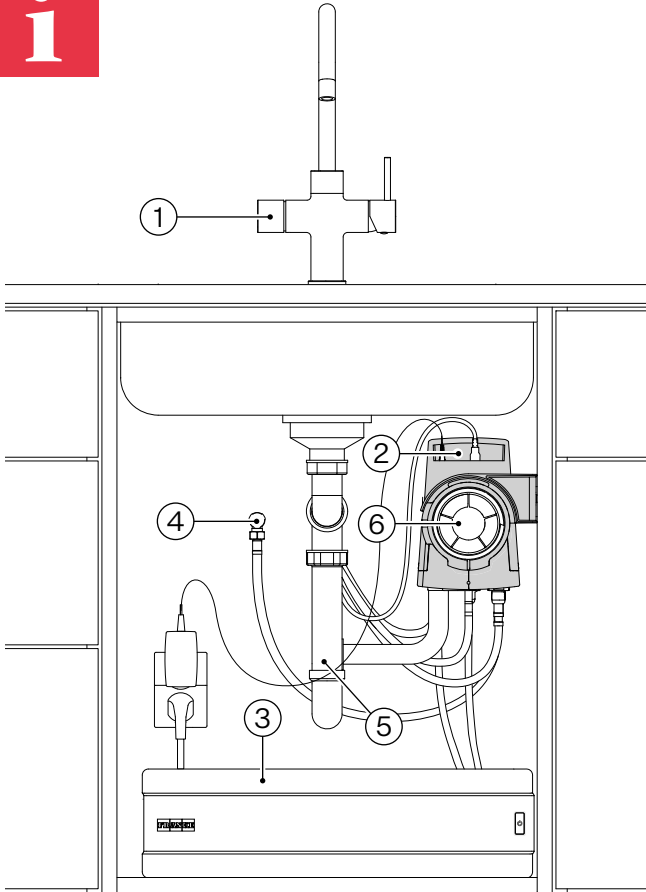

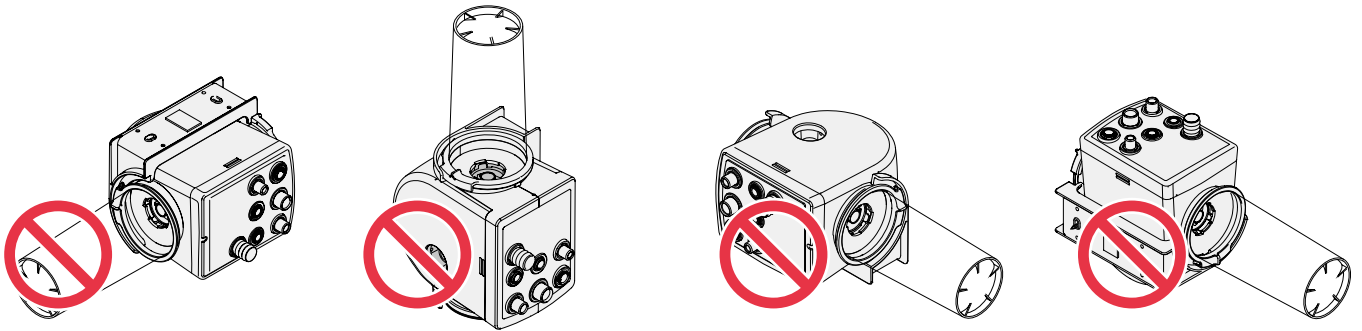

1

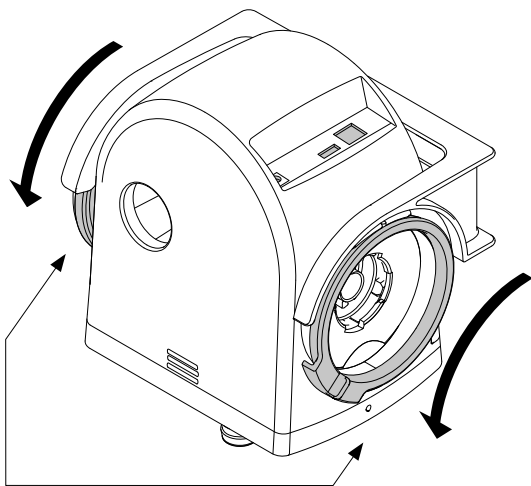

2

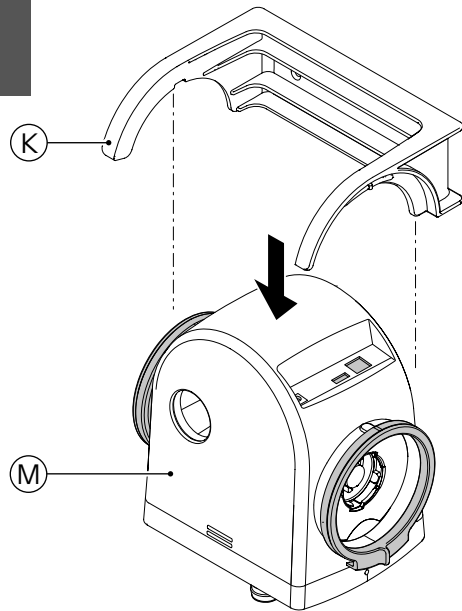

3

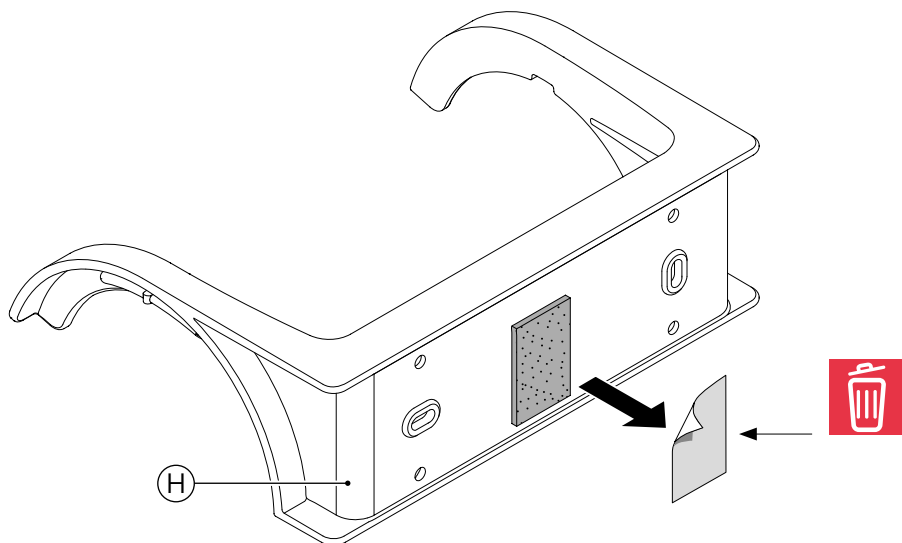

4

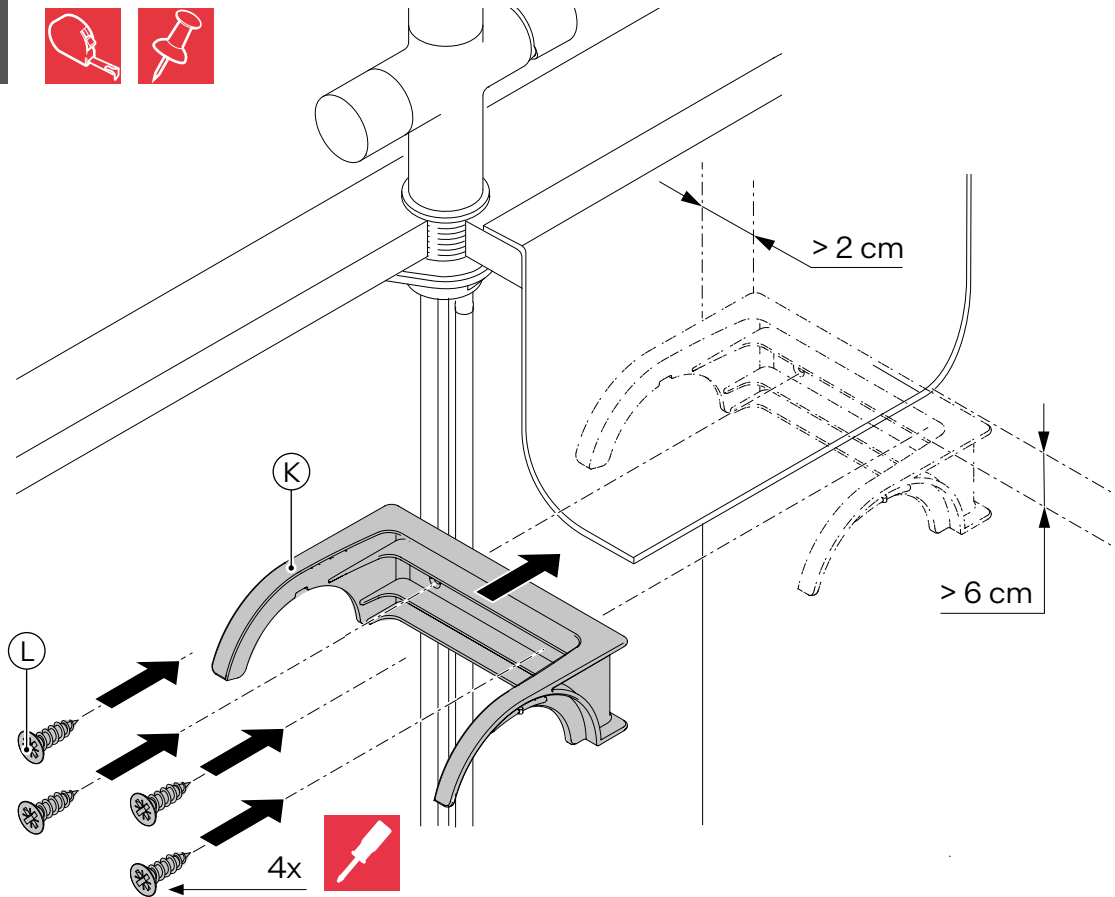

5

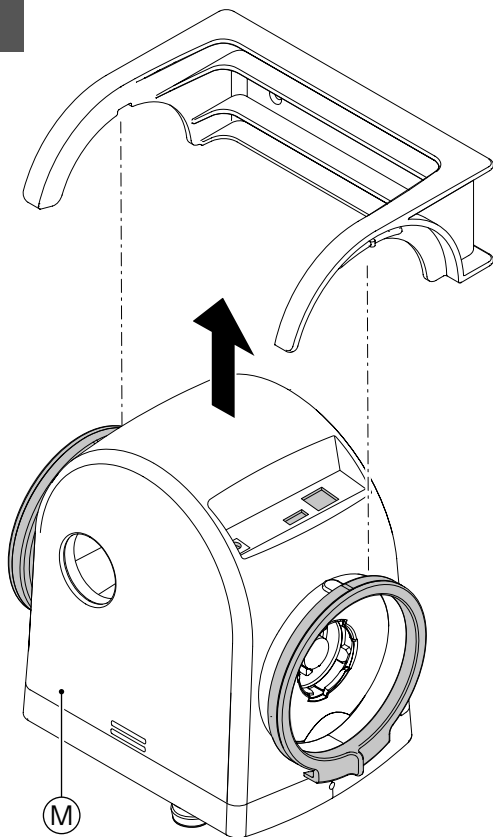

6

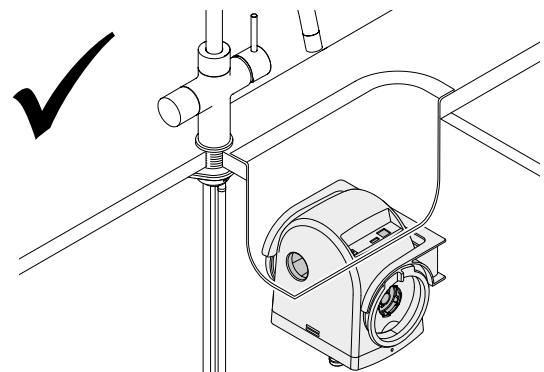
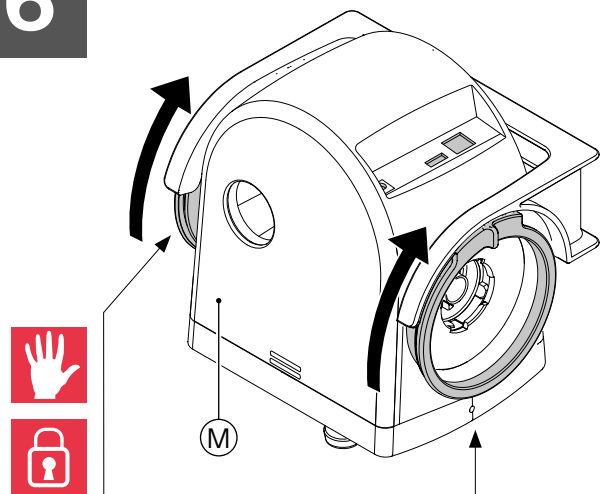

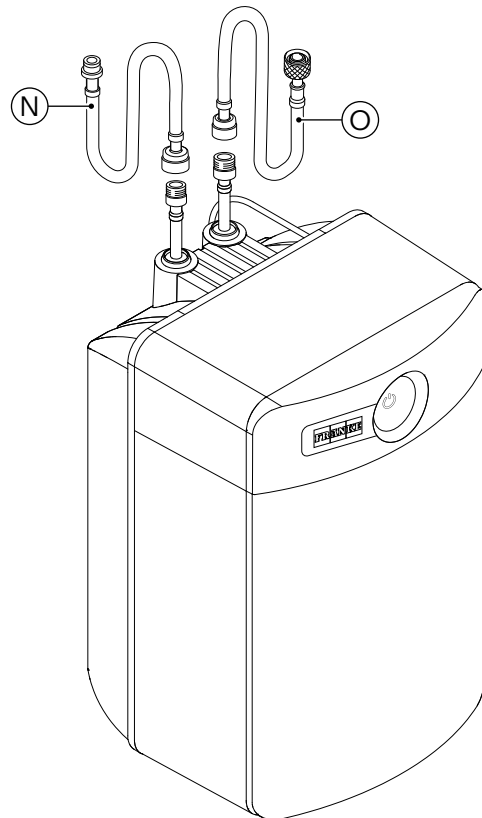
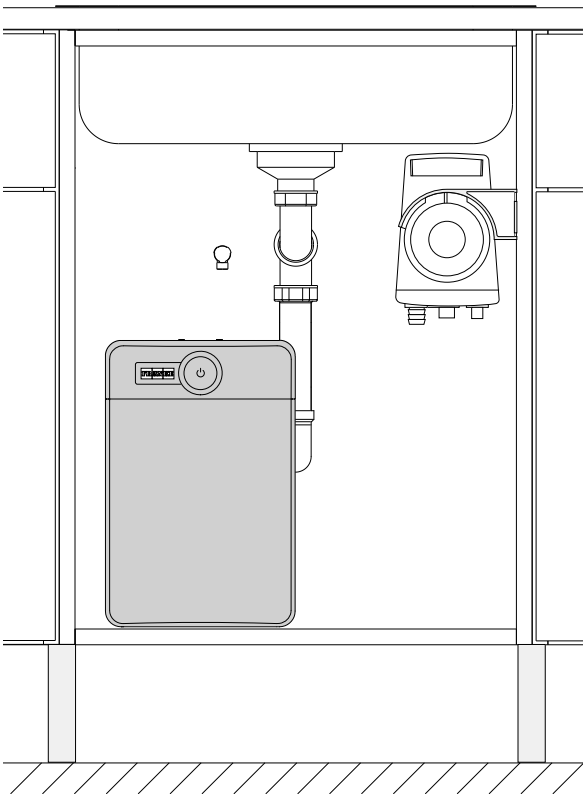
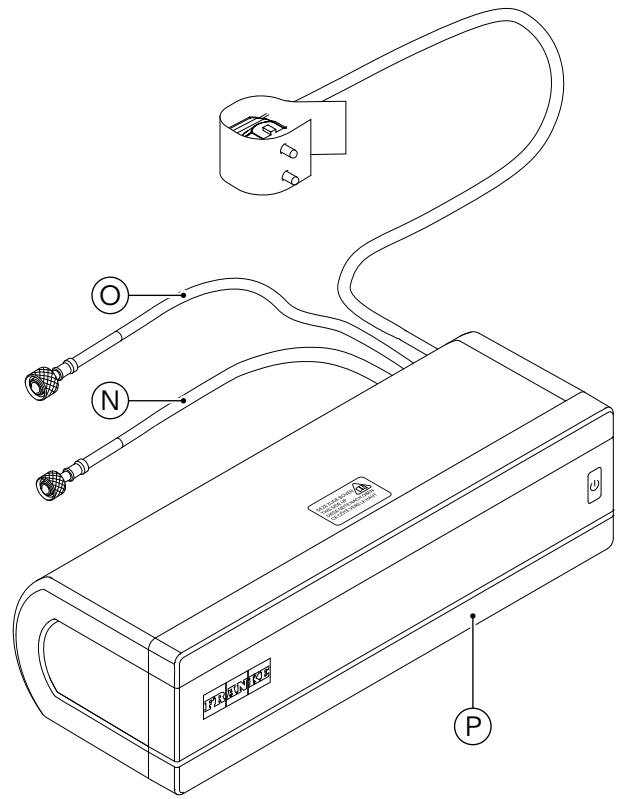
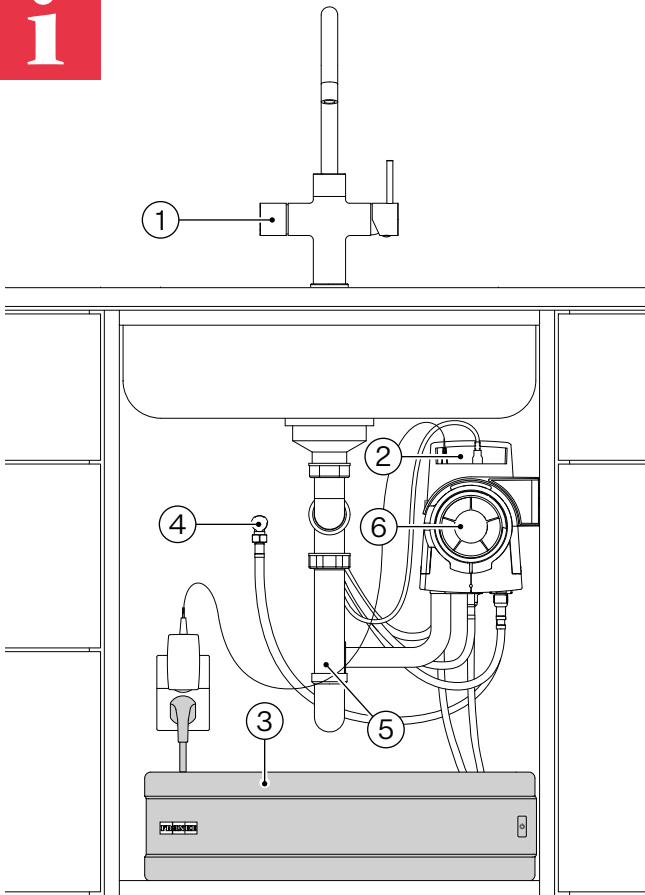



> 150 mm

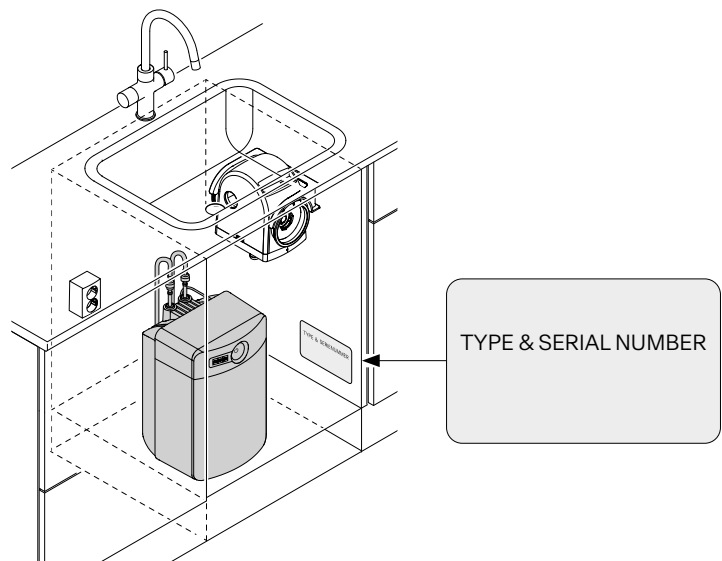
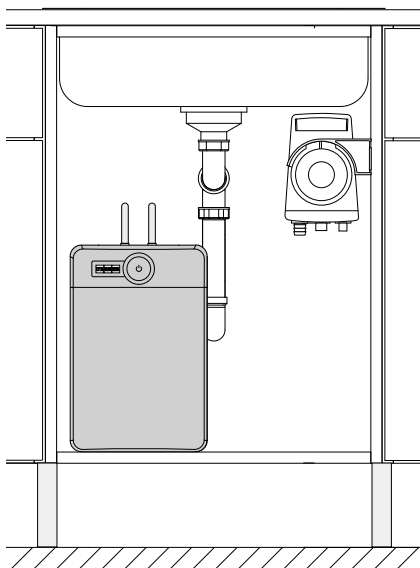
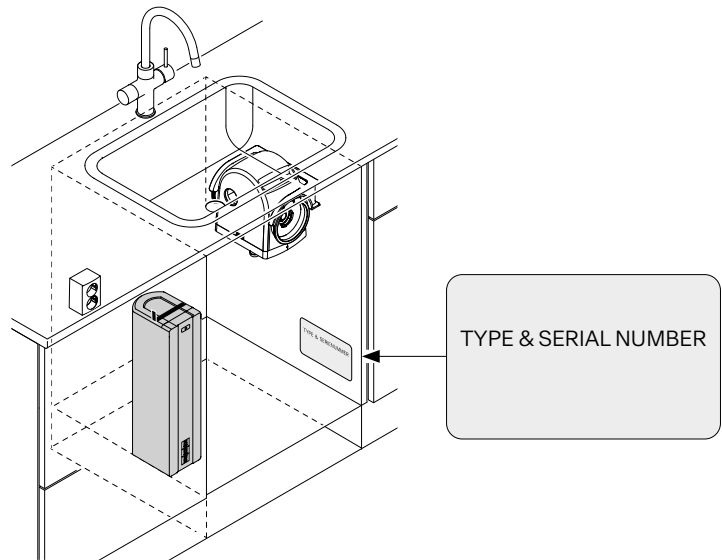
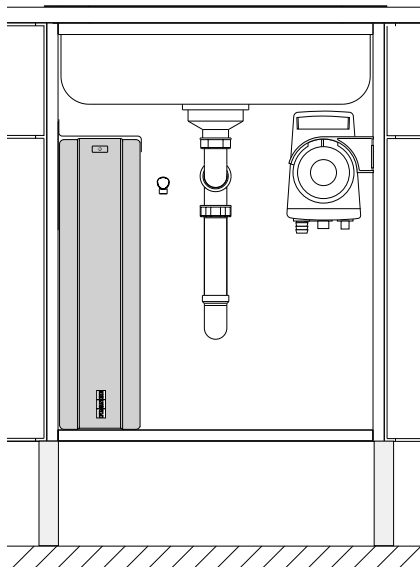
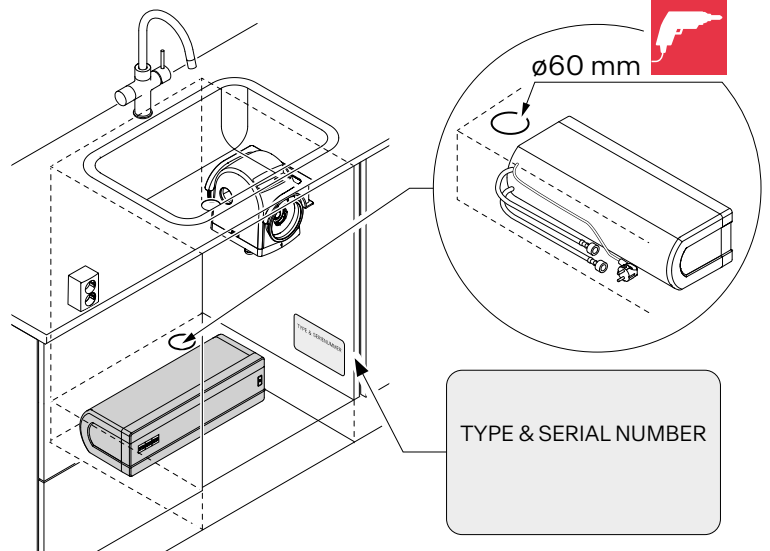
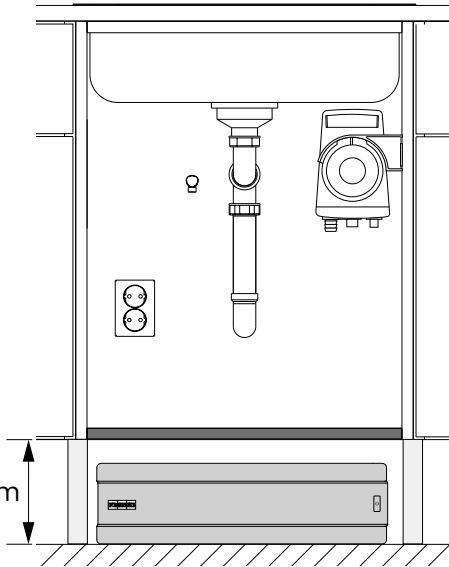

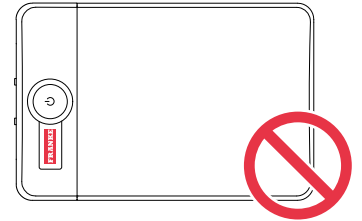
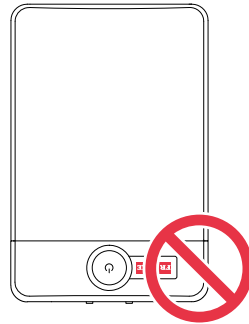
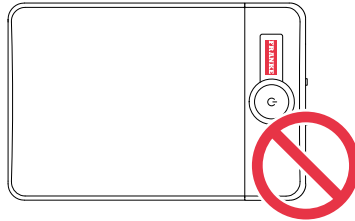
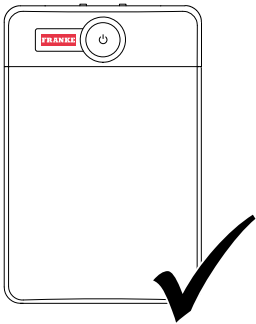
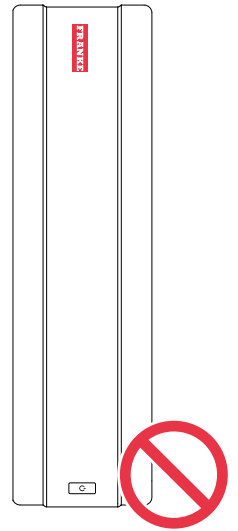
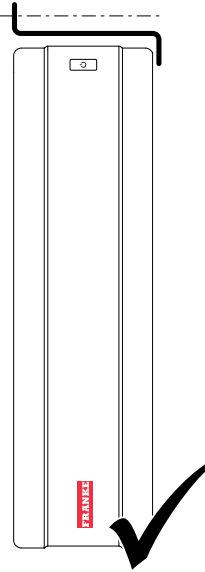
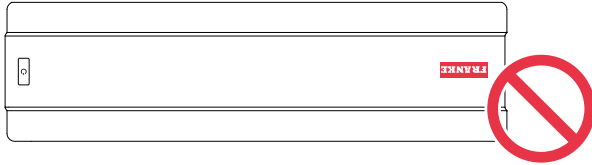
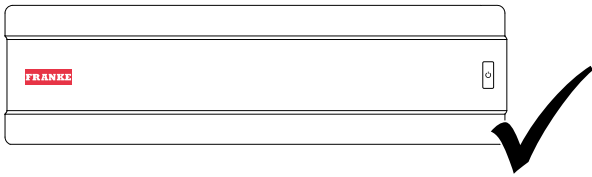

FIRST FILL THE WATER HEATER WITH WATER!
REPLIR D'ABORD LE BOILER AVEC L'EAU!

VUL EERST DE BOILER MET WATER!
ZUERST DEN SPEIGER MIT WASSER FÜLLEN!

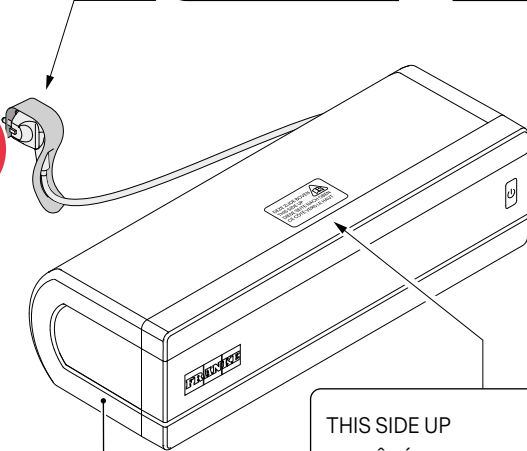

P



THIS SIDE UP
CE CÔTÉ VERS LE HAUT
DEZE ZIJDE BOVEN
DIESE SEITE NACH OBEN





1

Standard installation

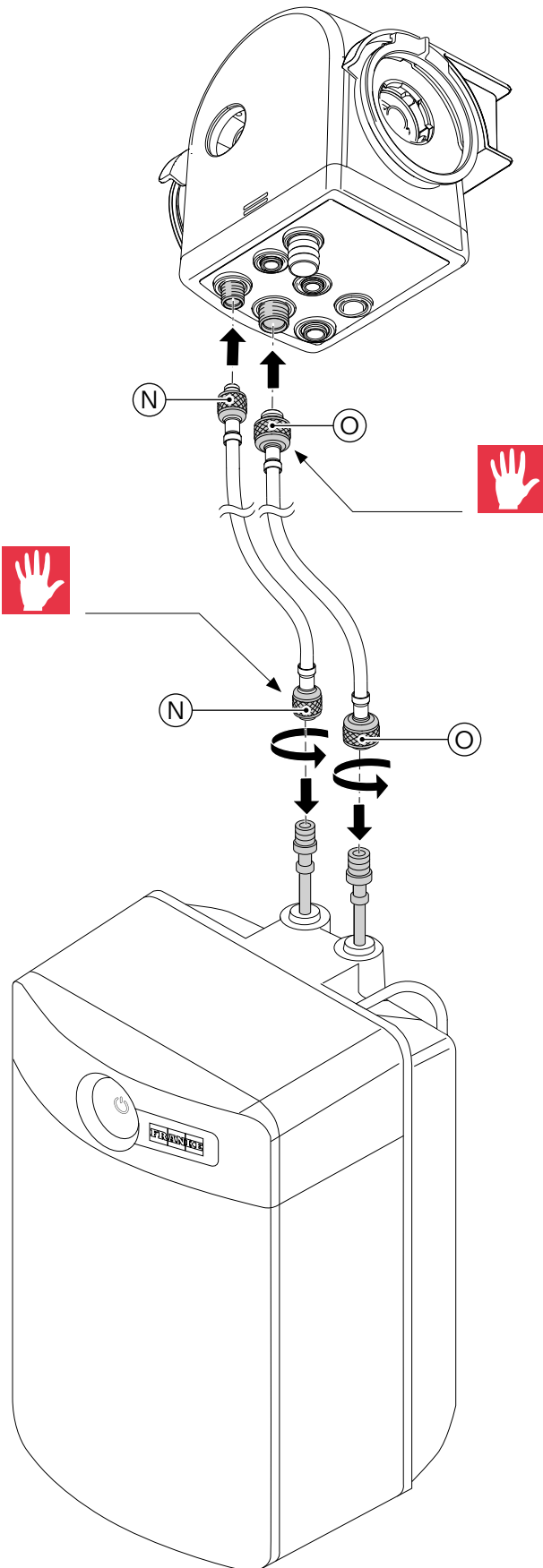

2

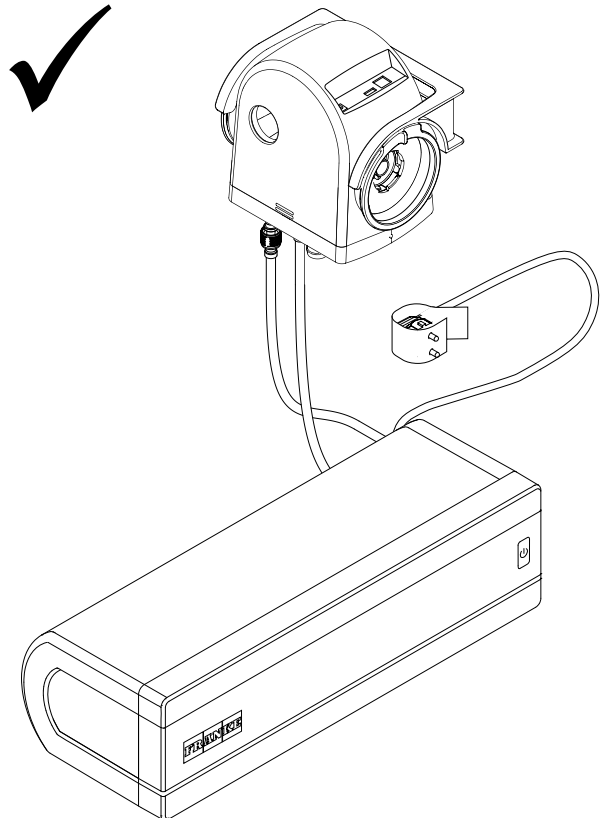
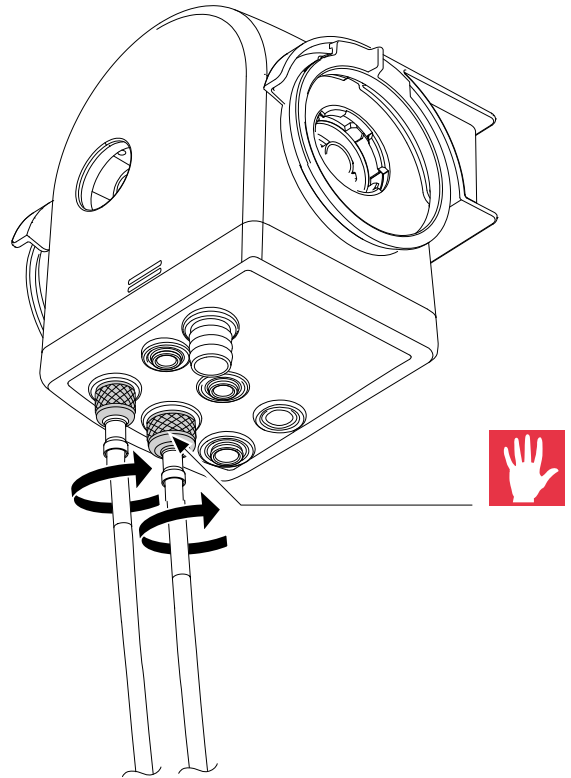

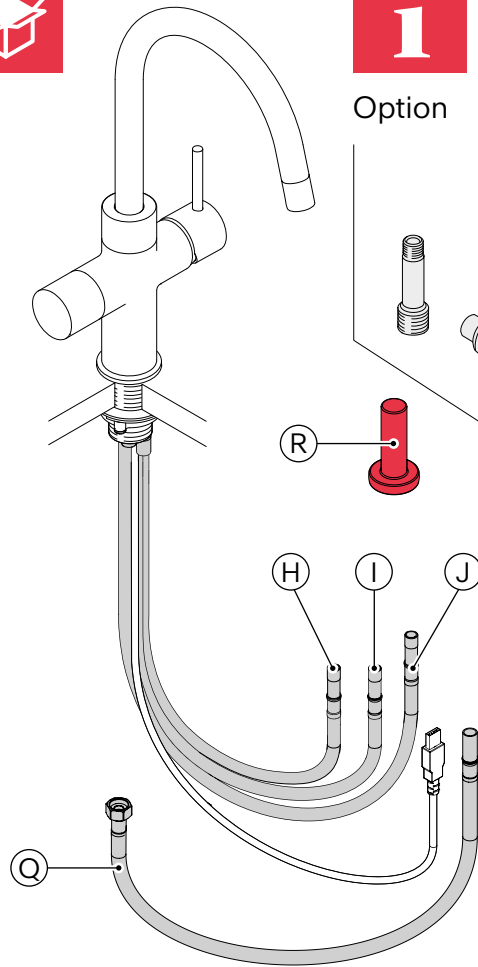
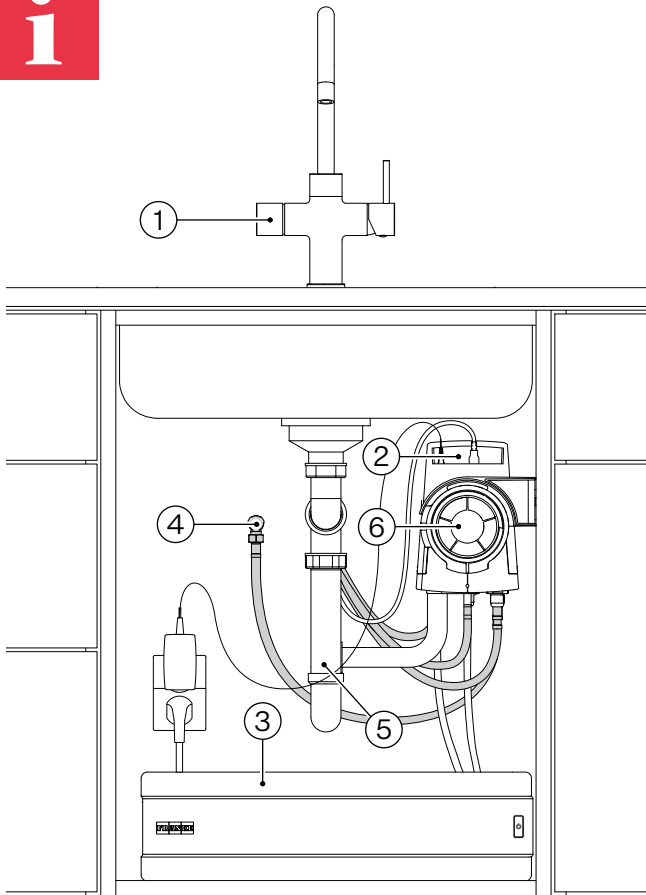

Option



1

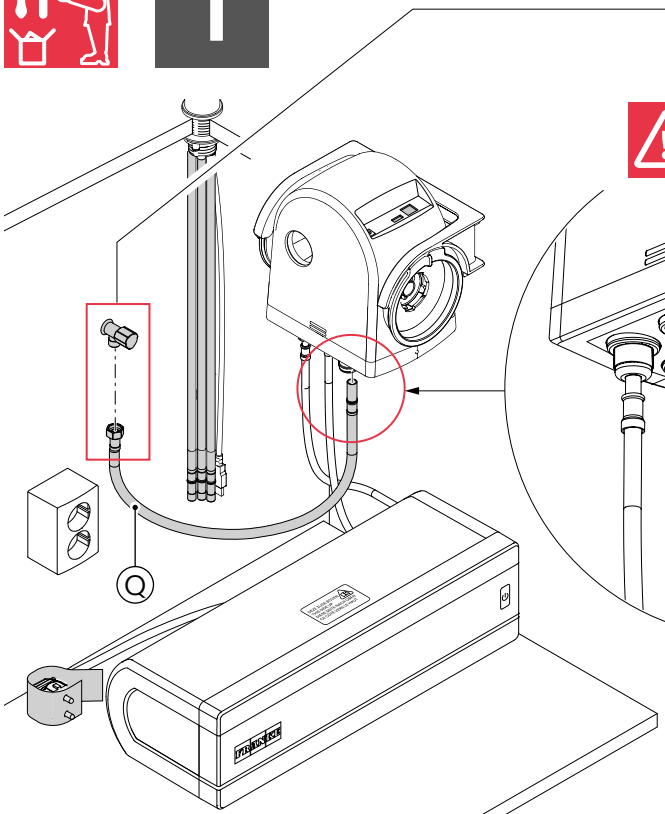

2

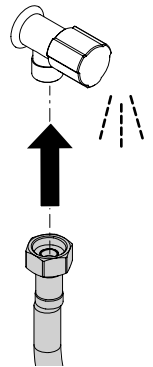

3

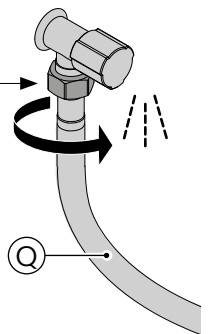

4

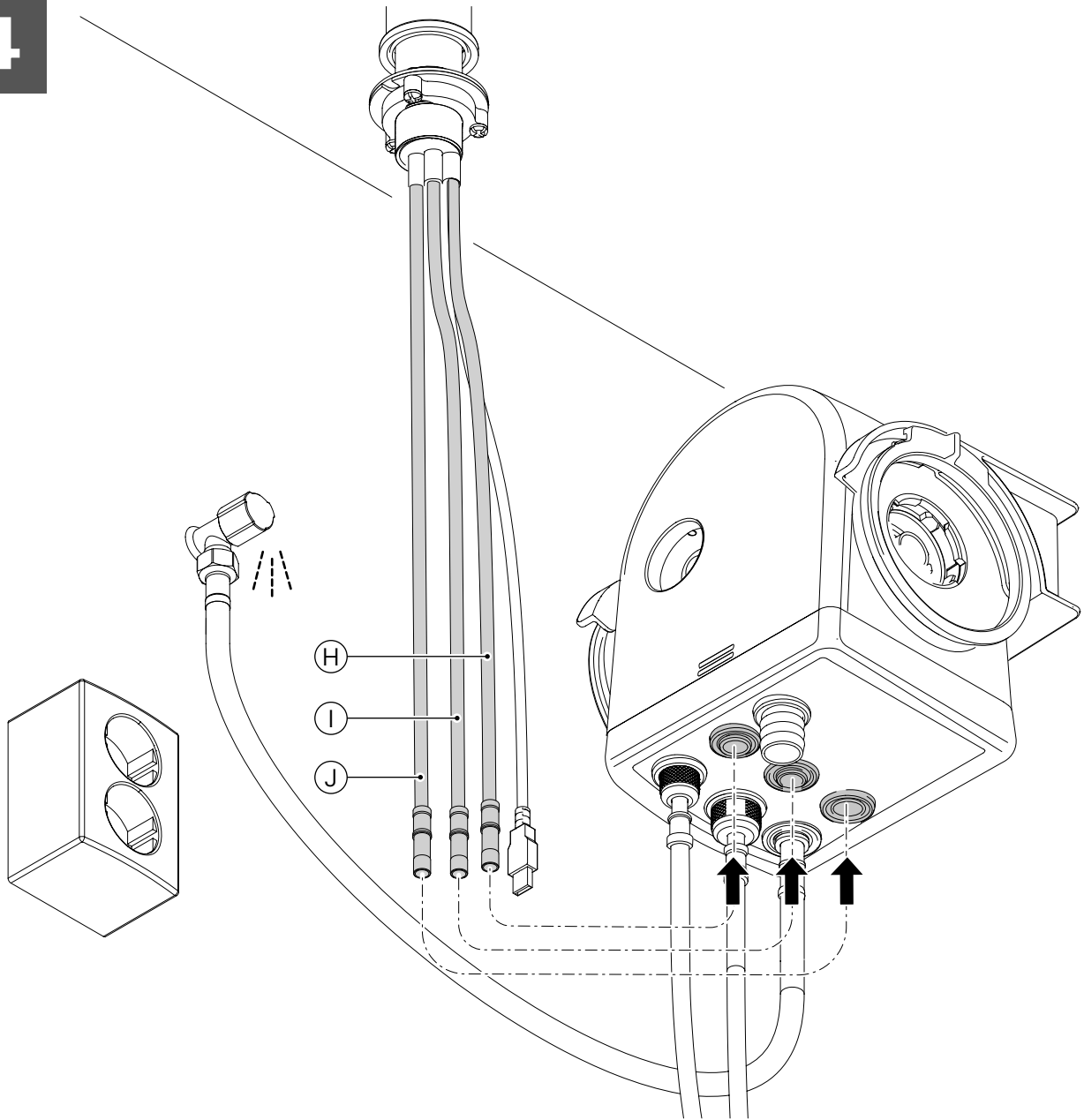

5

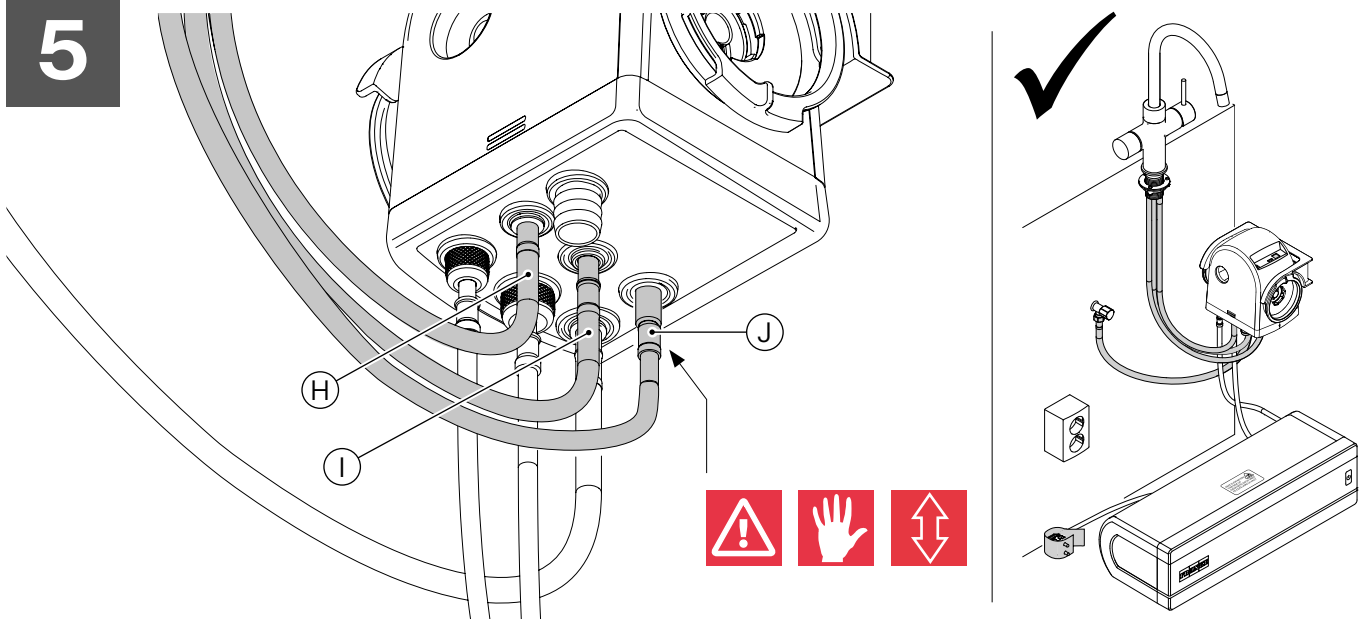

1

Hot water supply installation

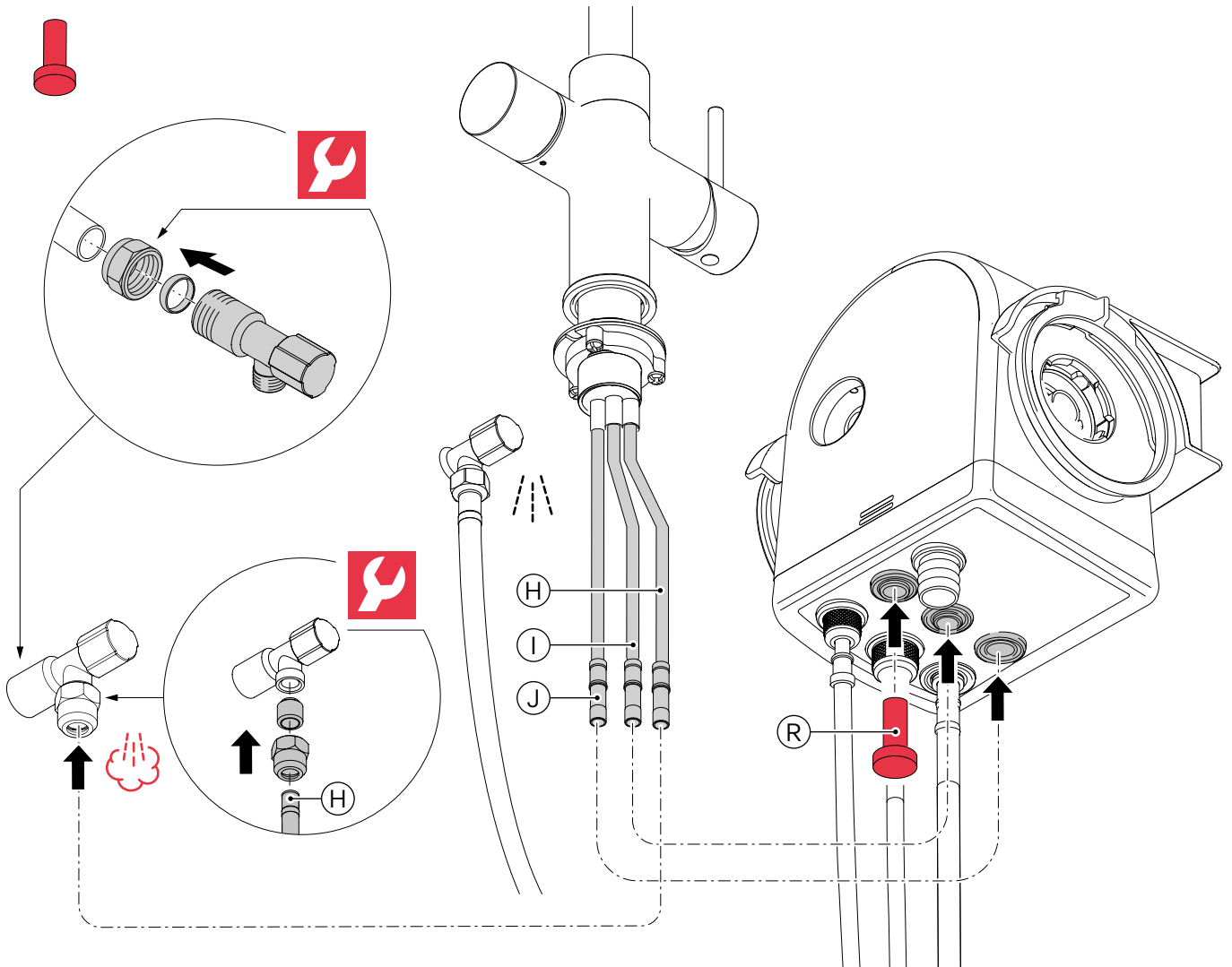

2

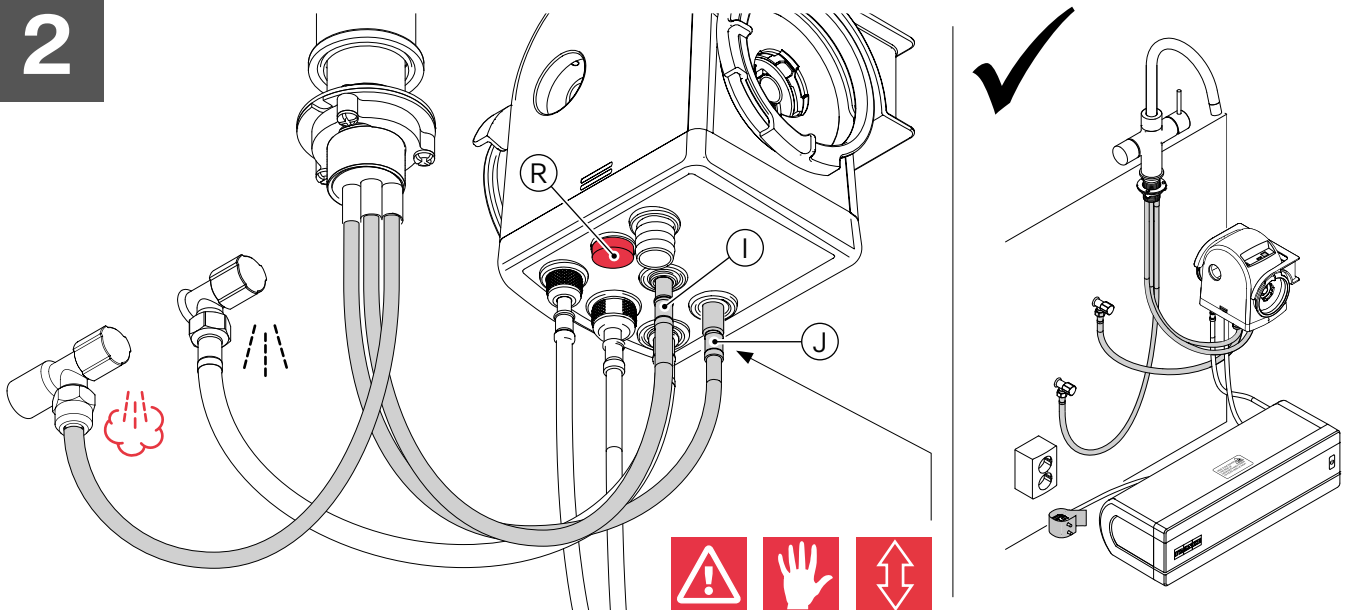

1

Optional Bypass installation

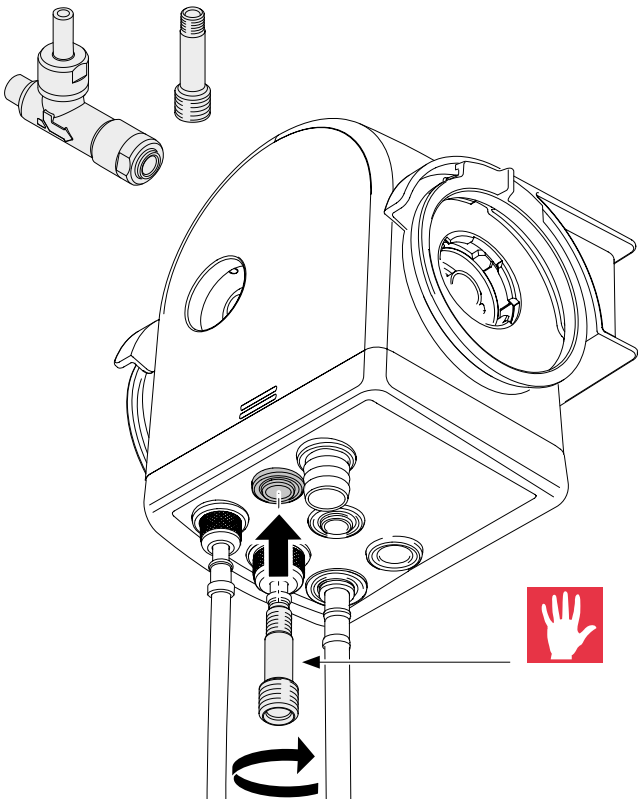
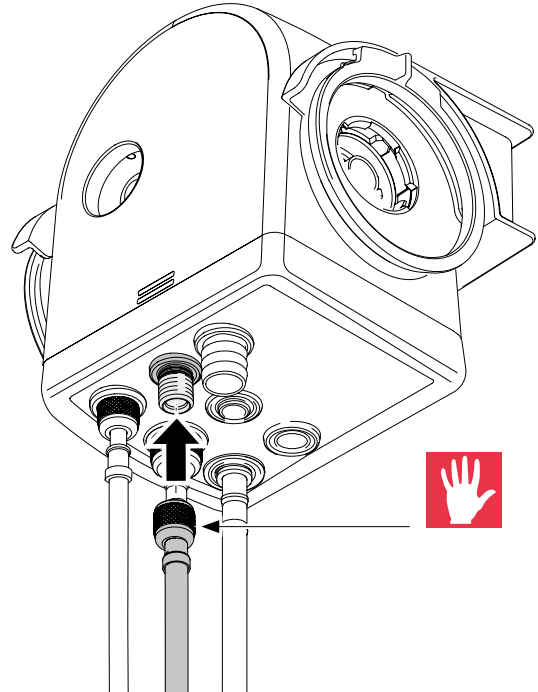
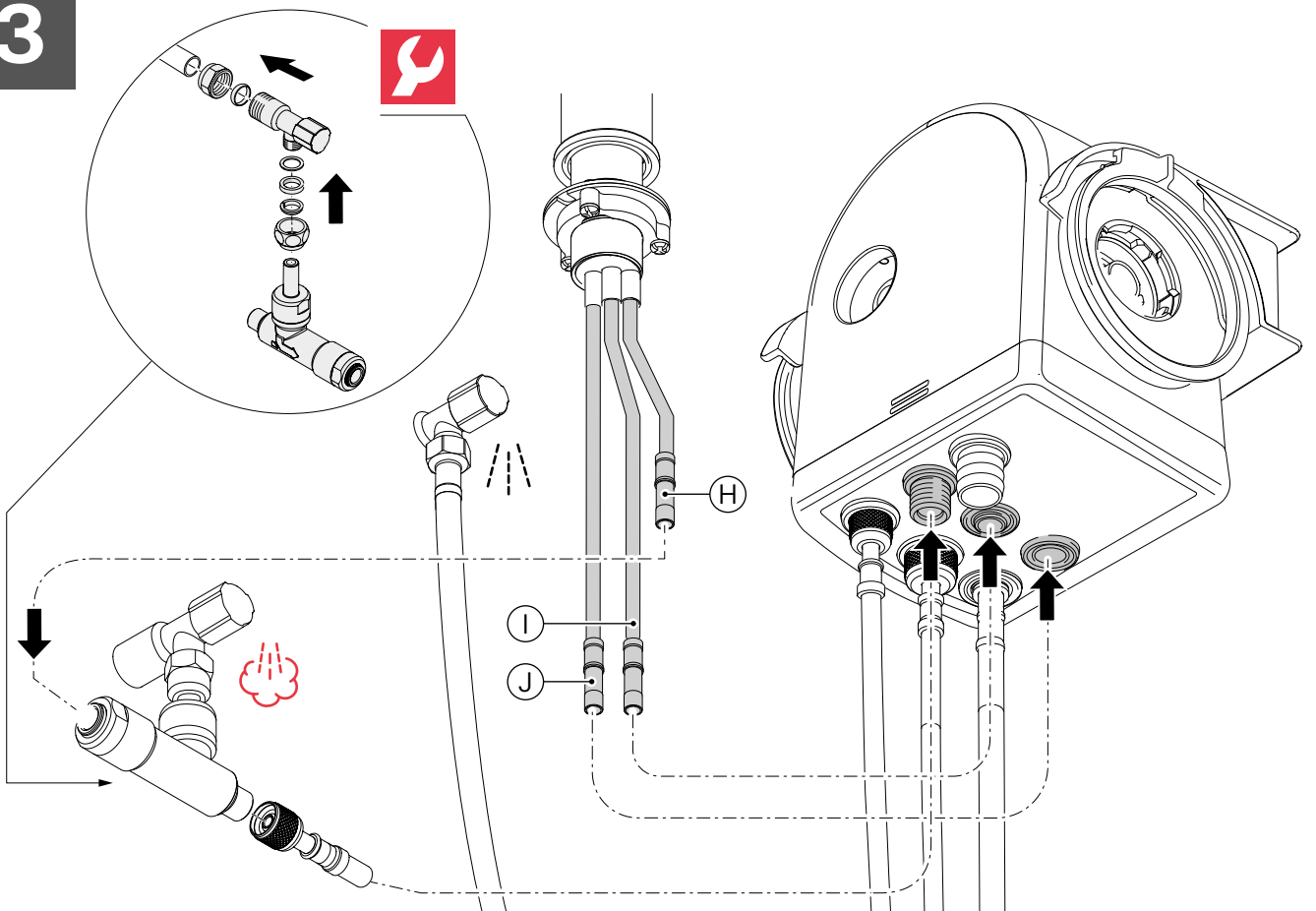
**2****3**

4

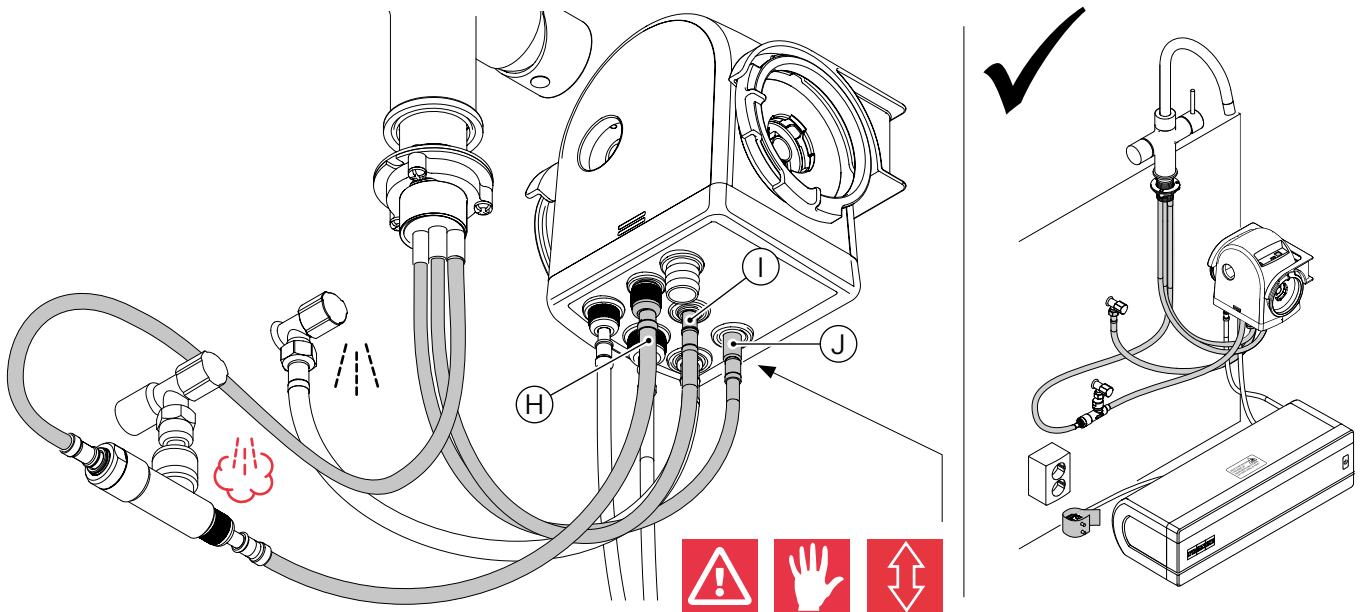
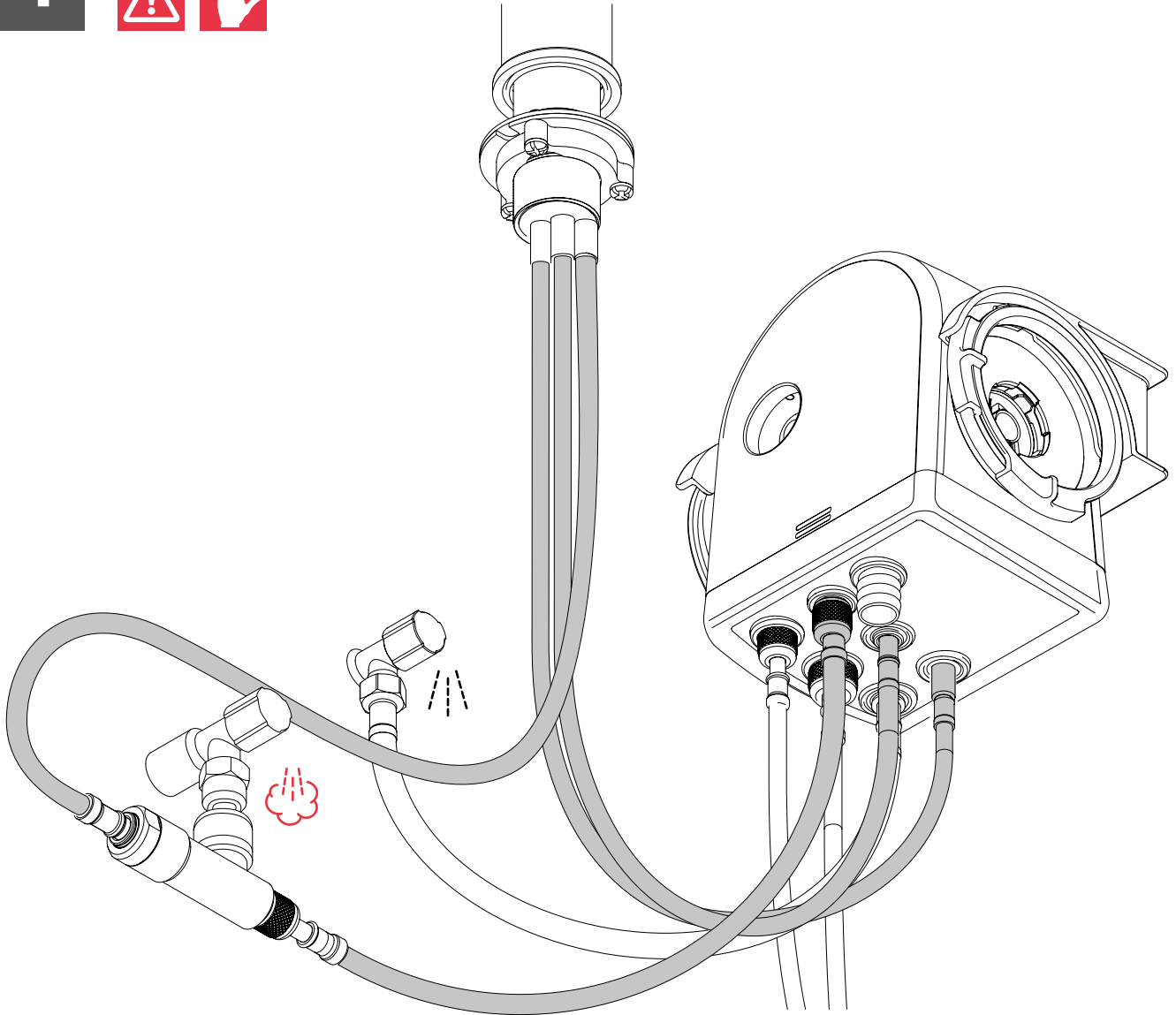

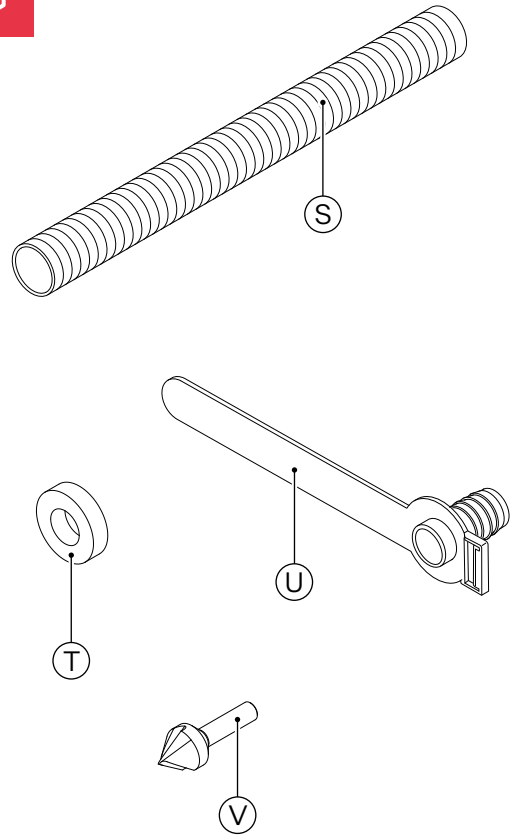
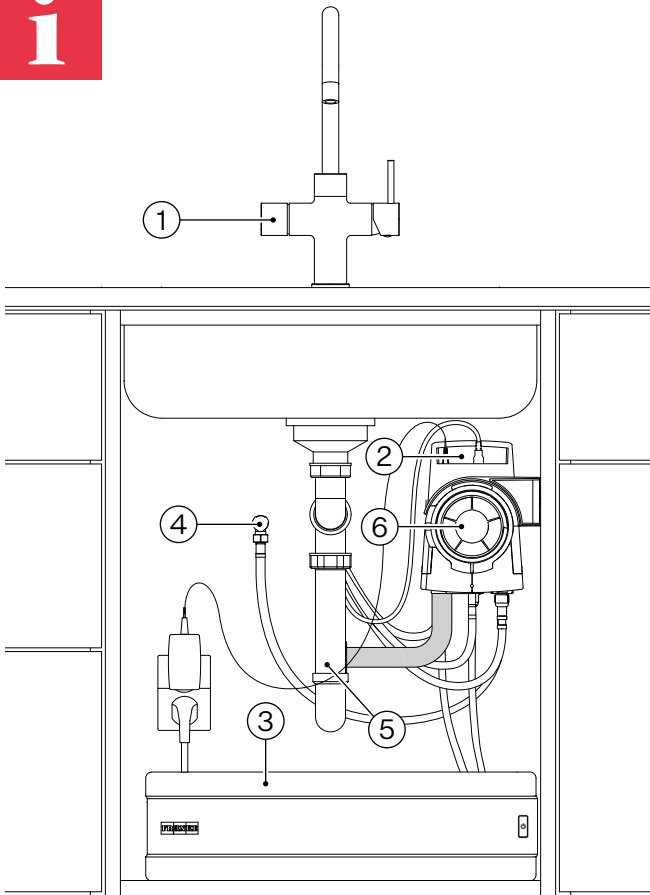

1

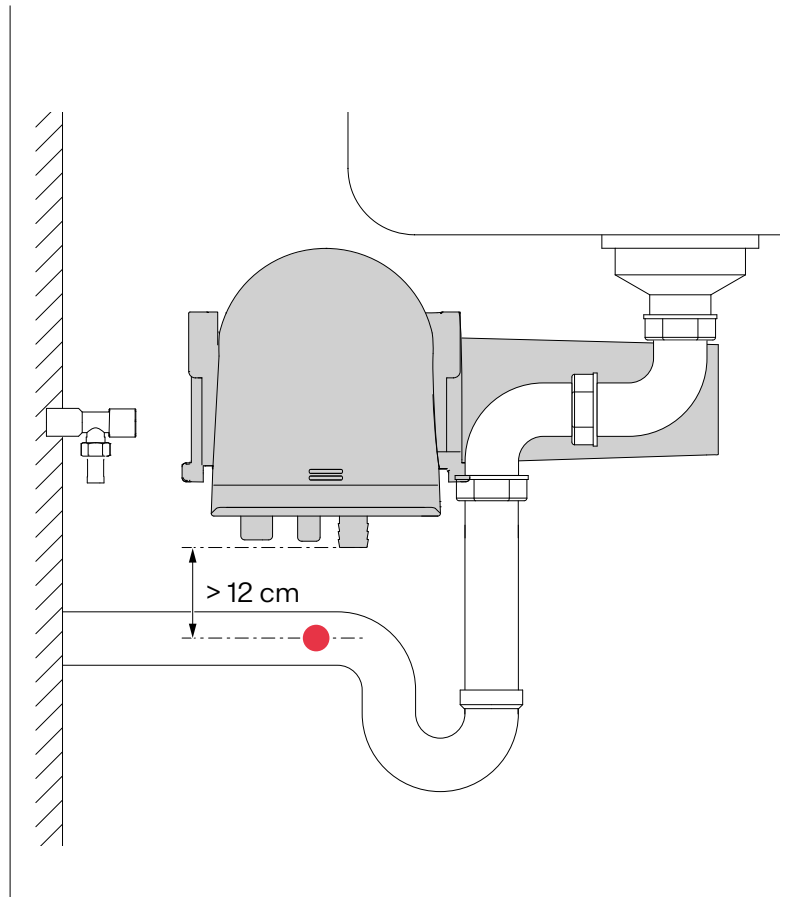
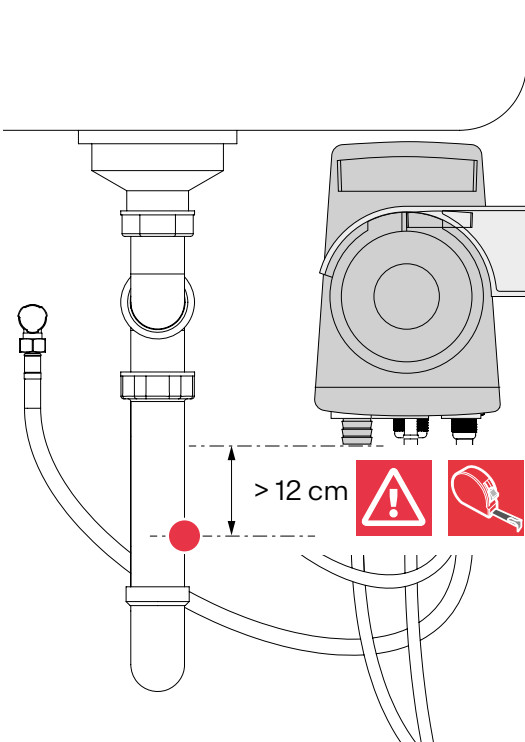

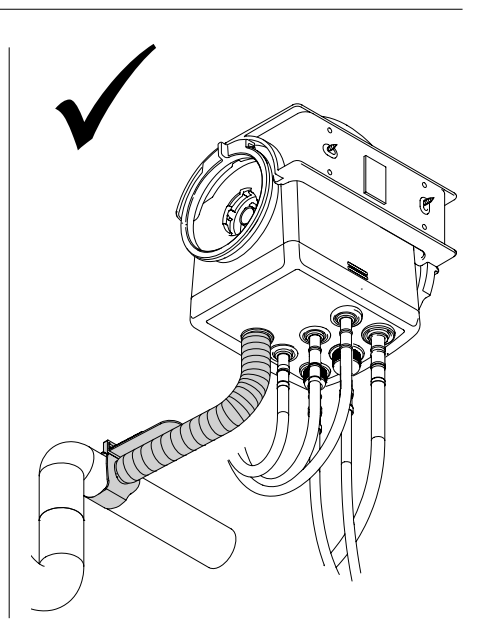
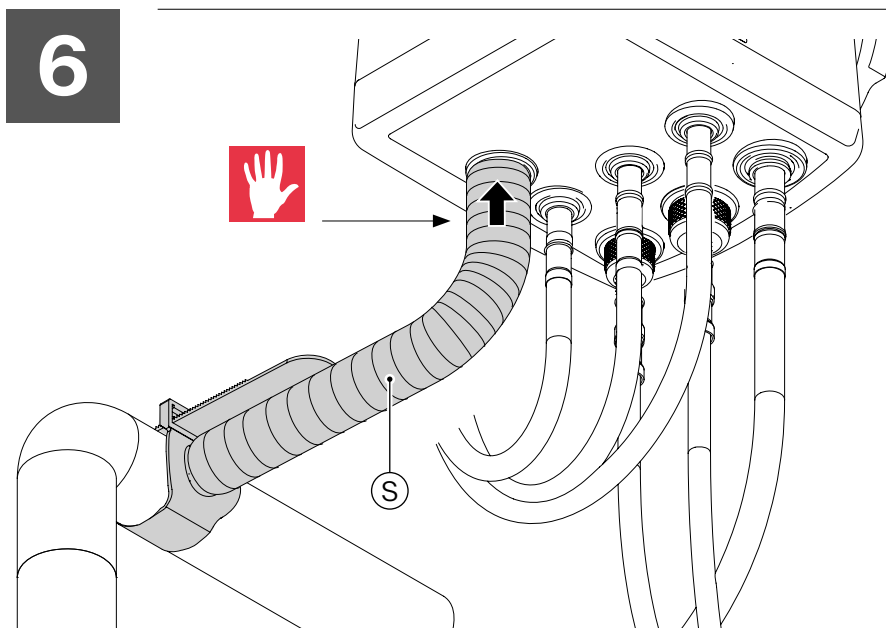
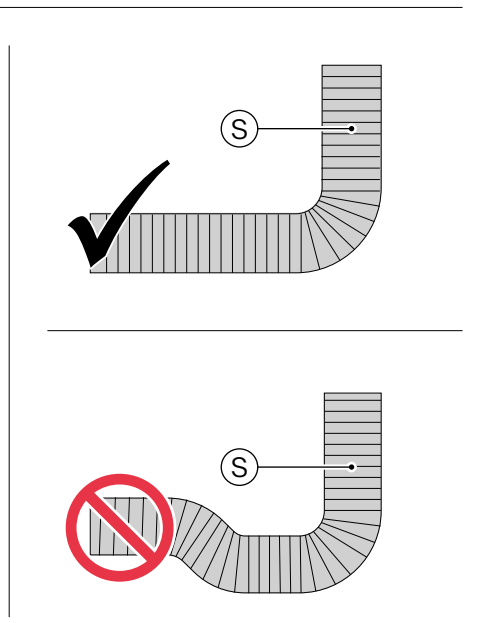
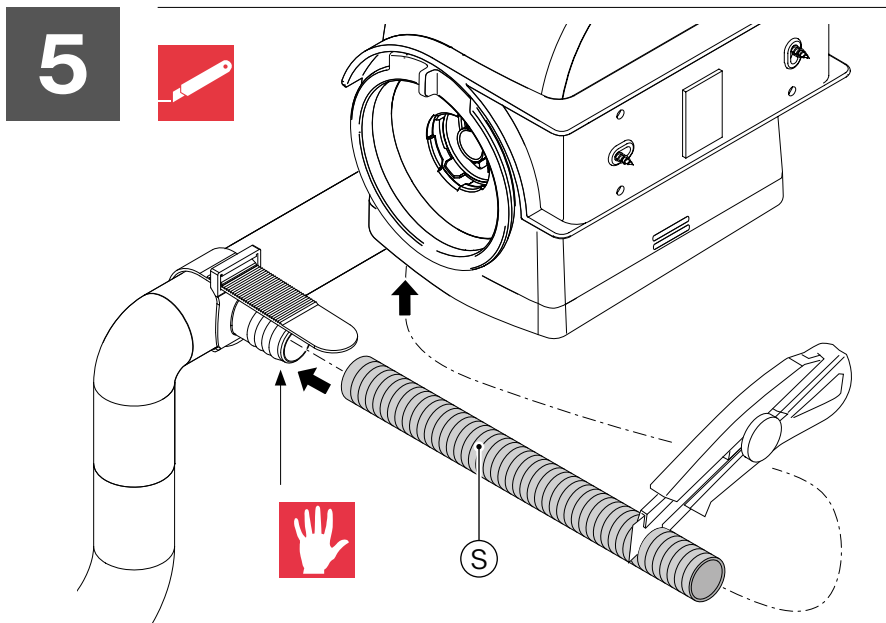
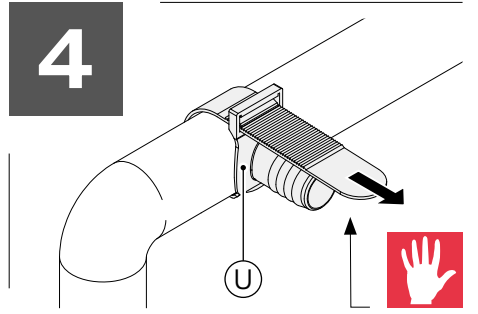
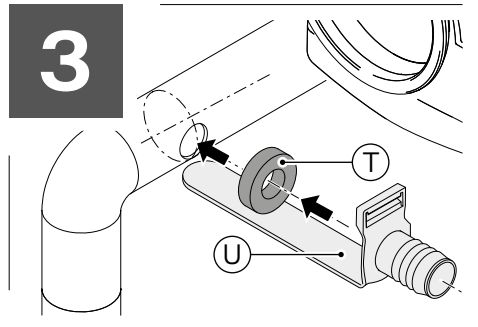
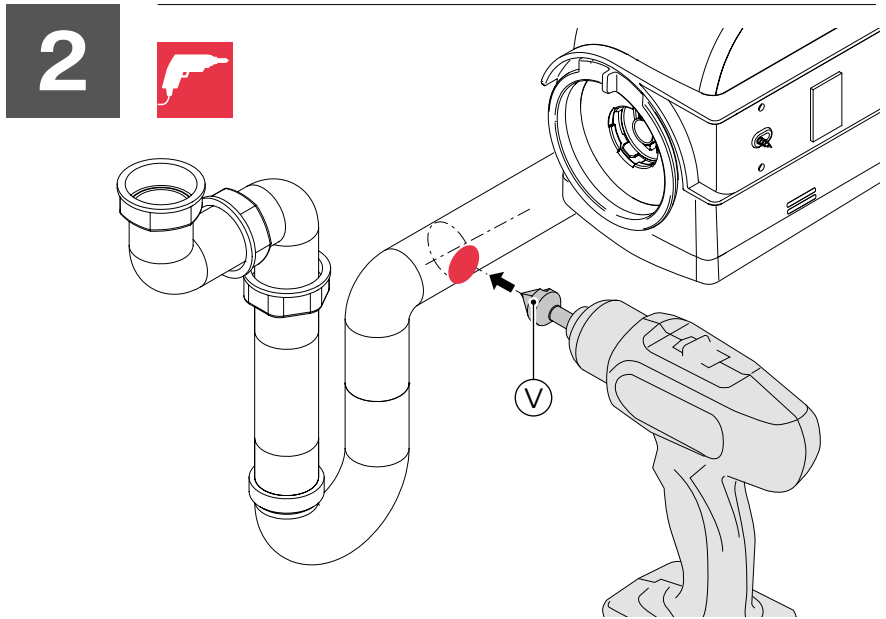

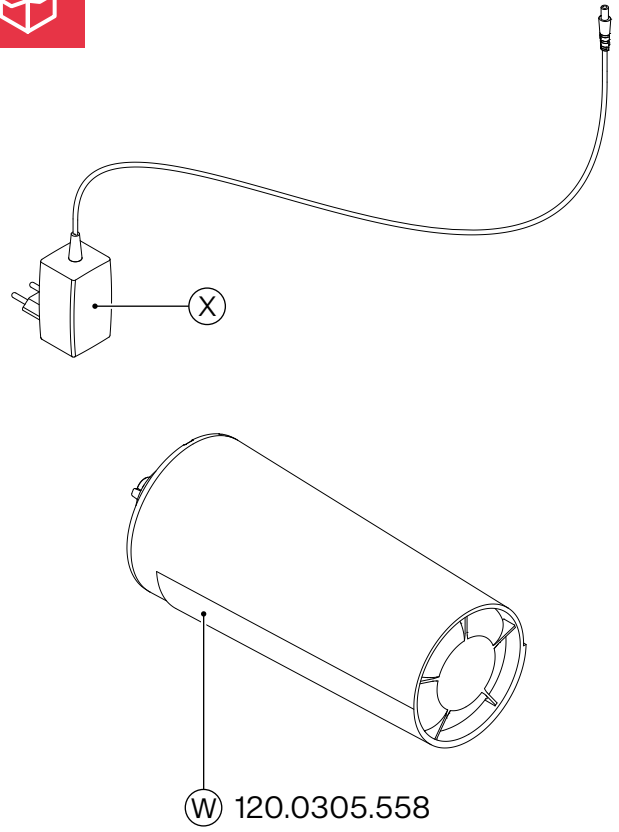
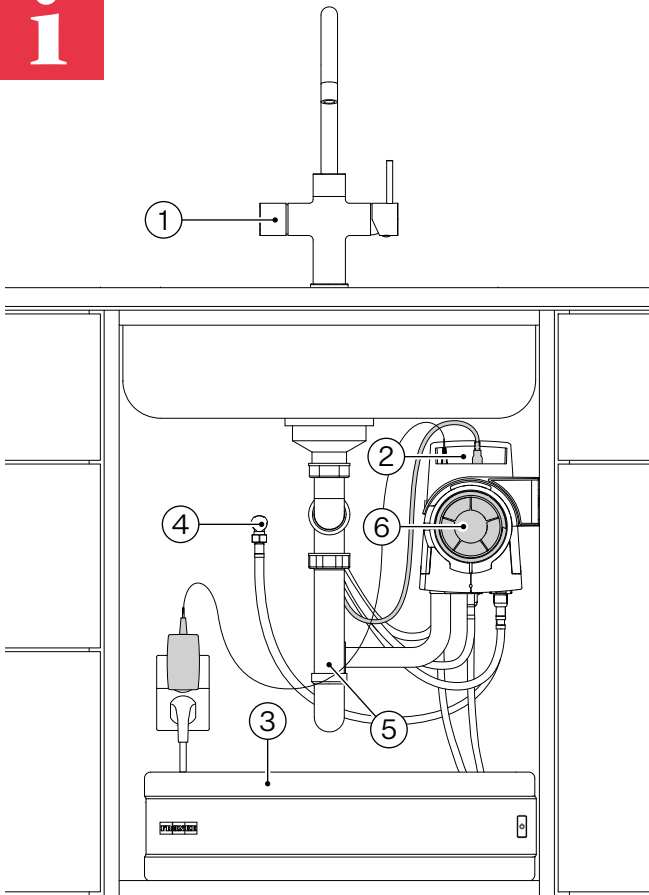

1

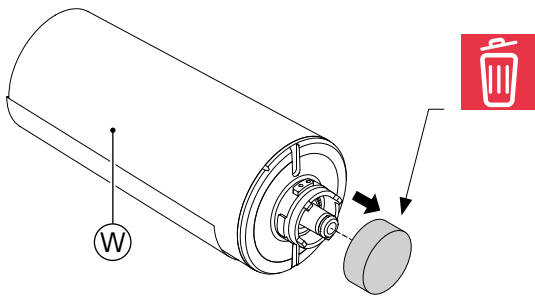

2

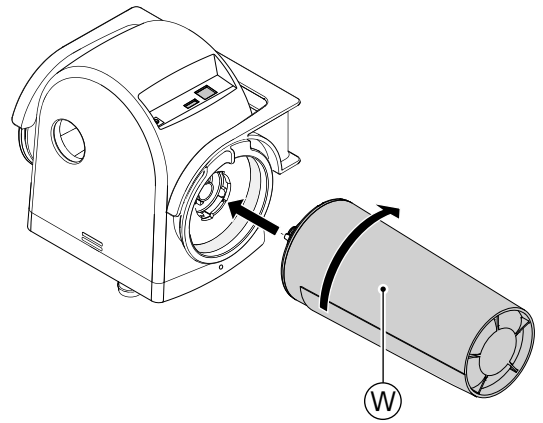

3

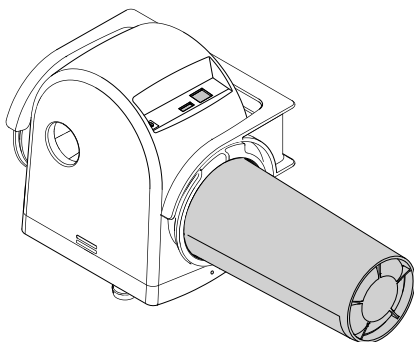

4

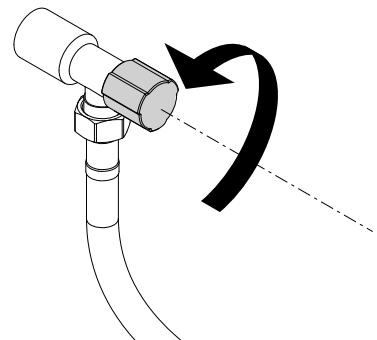

5

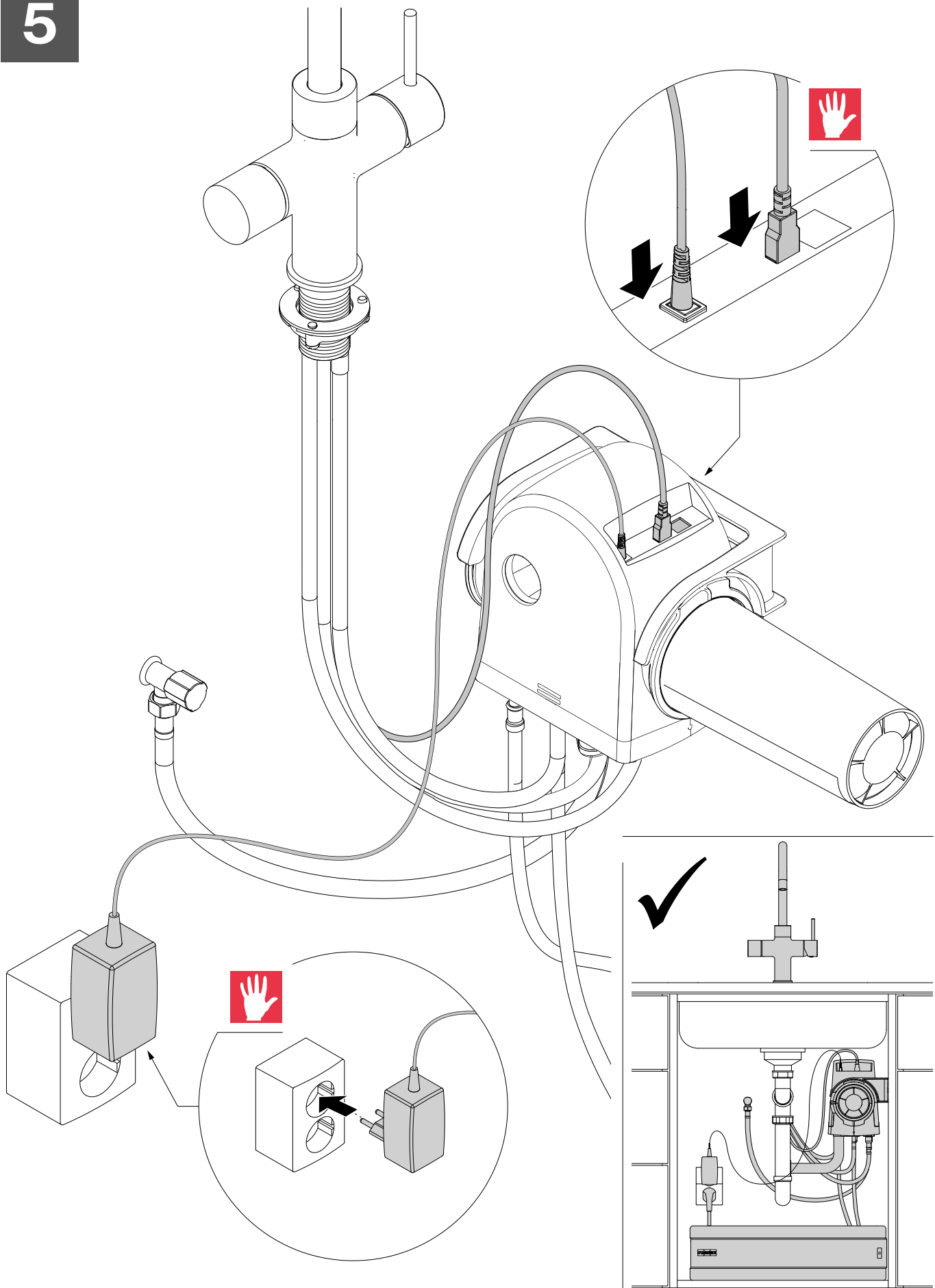

Argentina

Industrias Spar San Luis S.A.
Buenos Aires 1008
Phone +54 11 4311 7655

Australia

Franke AU
Melbourne 3175
Phone: +61 3 9700 9100

Belgium

Franke N.V.
9400 Ninove
Phone +32 54 310 111

Brazil

Franke Sistemas de
Cozinhas Ltda
89.219-600 Joinville-SC
Phone 0800-4773000

Canada

Franke Kindred Canada Ltd.
Midland, ON L4R 4K9
Phone +1 866 687 7465

China

Franke (China) Kitchen
Systems Co., Ltd.
Heshan, Guangdong, 529700
Phone 400 882 9898

Czech Republic

Franke s.r.o.
190 00 Praha 9
Phone +420 281 090 445

Denmark

Franke KS Denmark
8520 Lystrup
Phone +45 8624 9024

Egypt

Al Sharq for Ceramic and
Porcelain - Mozdan
Nasr City, Cairo, Egypt
Phone +201000038122

Finland

Franke Finland Oy
76850 Naarajärvi
Phone +358 15 341 11

France

Franke France S.A.S.
60230 Chambly
Phone +33 130 289 400

Germany

Franke GmbH
79713 Bad Säckingen
Phone +49 7761 52 199

Greece

Franke Hellas S.A.
19003 Markopoulo Attikis
(Athens)
Phone +30 22991 500 00

Hong Kong SAR

Franke Asia Hong Kong
Quarry Bay
Phone +852 3184 1900

India

Franke Faber India Private
Limited
Pune 412208
Phone 1800 209 3484

Italy

Franke S.p.A.
37019 Peschiera del Garda
Toll-free number 800 359 359

Kazakhstan

Franke Kazakhstan Ltd.
040918 Almaty City
Phone +7 727 297 3812

New Zealand

PR Kitchens
Auckland 2150
Phone + 64 9 964 0400

Norway

Franke KS Norway
8520 Lystrup, Denmark
Phone +47 35 566 450

Poland

Franke Polska Sp. z o.o.
05-090 Raszyn
Phone +48 22 711 6700

Portugal

Franke Portugal S.A.
2735-531 Cacém
Phone +351 21 426 9670

Romania

Franke Romania SRL
Pantelimon 077145
Phone +40 21 350 1550

Russia

Franke Russia GmbH
248033 Kaluga
Phone +7 800 555 1255

Singapore

Franke Singapore Pte Ltd
33 Ubi Ave 3
01-38 Vertex
Phone +65 9838 2542

Slovak Republic

Franke Slovakia s.r.o.
013 24 Strečno
Phone +420 281 090 445

South Africa

Franke South Africa
Durban 4052
Phone +27 31 450 6300

Spain

Franke España S.A.U.
08174 Sant Cugat del Vallès
Phone +34 934 456 768

Sweden

Franke Futurum AB
930 47 Byske
Phone +46 912 405 00

Switzerland

Franke Küchentechnik AG
4663 Aarburg
Phone +41 800 583 243

Thailand

Franke (Thailand) Co., Ltd.
Bangkok 10110
Phone +66 2 013 7900

The Netherlands

Franke Nederland BV
5611 ZX Eindhoven
Phone +31 85 0261 15 11

Turkey

Franke Mutfak ve Banyo
Sistemleri Sanayi
ve Ticaret A.S.
41480 Gebze Kocaeli/Turkey
Phone +90 262 644 6595

Ukraine

Franke Ukraina LLC
01042 Kyiv
Phone 0 800 301 801

United Arab Emirates

Franke LLC
Ras Al Khaimah
Phone +971 7 203 4700

United Kingdom

Franke UK Ltd.
Manchester M22 5WB
Phone +44 161 436 6280

USA

Franke Home Solutions, LLC
Smyrna, TN 37167
Phone 1 800 626 5771