

SUPPLY CABLE CONNECTION OPTIONS
SUPPLY CORD 4X2.5mmq H05V2V2-F

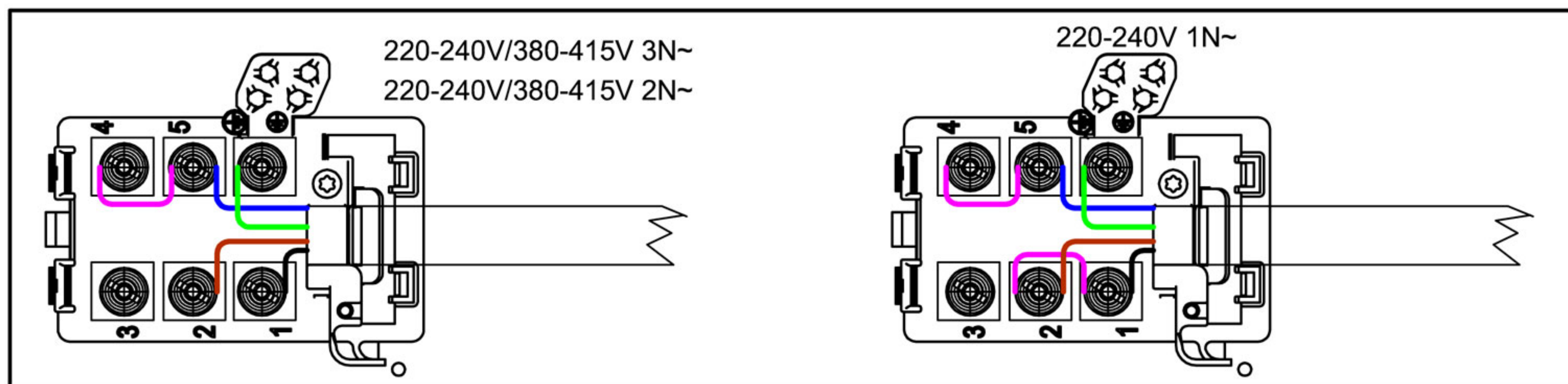

Drawn by	ZI998	04/10/2016	Replaced through		Thickness	Shear size	X	Weight
Checked by			Replacement for		Part Gr.	Part / Tool No.		Tolerance
Modified by	ZI998	03/02/2017	Originate from		Material			ISO 2768 m
Revision Description: Moved Fixing Tie Position			Unit	mm	Scale	NTS	Remark	
			Department:	Kitchen Systems		Project	Hobs	Collection
					SMART IND. MOD.-TERM. WIRING L=500+750		Electr_sch_hobs	
			Franke S.p.A. via Pignolini 2 37019 Peschiera del Garda VR, Italy Switchboard: +39 045 6449311 Fax: +39 049 7552598 E-Mail: info@fp.franke.com Internet: www.franke.it		WIRING SCHEME CODE 4			
			These drawings and specifications are the property of Franke Technology and Trademark Ltd. and shall not be reproduced, copied or transferred to any third party without the prior written permission of Franke Technology and Trademark Ltd., Hergiswil, Switzerland		Format	A3	Drawing No.	0006-112386
							Rev.	B